

MSI Pro266TD Master
MICRO-STAR INTERNATIONAL Pro266TD Master-LR
MS-9105 ATX Mainboard



Version 1.0
G52-MA00436

Manual Rev: 1.0
Release Date: October 2001



FCC-B Radio Frequency Interference Statement

This equipment has been tested and found to comply with the limits for a class B digital device, pursuant to part 15 of the FCC rules. These limits are designed to provide reasonable protection against harmful interference when the equipment is operated in a commercial environment. This equipment generates, uses and can radiate radio frequency energy and, if not installed and used in accordance with the instruction manual, may cause harmful interference to radio communications. Operation of this equipment in a residential area is likely to cause harmful interference, in which case the user will be required to correct the interference at his own expense.

Notice 1

The changes or modifications not expressly approved by the party responsible for compliance could void the user's authority to operate the equipment.

Notice 2

Shielded interface cables and A.C. power cord, if any, must be used in order to comply with the emission limits.

VOIR LA NOTICE D'INSTALLATION AVANT DE RACCORDER AU RESEAU.

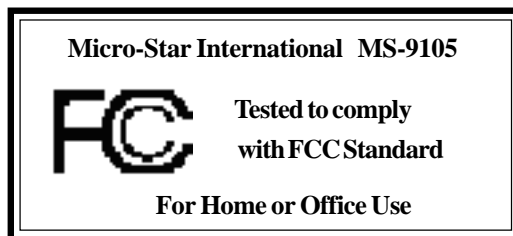

Edition

October 2001

Copyright Notice

The material in this document is the intellectual property of **MICRO-STAR INTERNATIONAL**. We take every care in the preparation of this document, but no guarantee is given as to the correctness of its contents. Our products are under continual improvement and we reserve the right to make changes without notice.

Trademarks

All trademarks used in this manual are the property of their respective owners.

Intel and Pentium are registered trademarks of Intel Corporation.

PS/2 and OS/2 are registered trademarks of IBM Corporation.

Windows 98/2000/ME and Windows NT are registered trademarks of Microsoft.

Netware is a registered trademark of Novell.

Award is a registered trademark of Award Software Inc.

Revision History

Revision	Revision History	Date
1.0	First release	October 2001

Safety Instructions

1. Always read the safety instructions carefully.
2. Keep this User's Manual for future reference.
3. Keep this equipment away from humidity.
4. Lay this equipment on a reliable flat surface before setting it up.
5. The openings on the enclosure are for air convection hence protects the equipment from overheating. **DO NOT COVER THE OPENINGS.**
6. Make sure the voltage of the power source and adjust properly 110/220V before connecting the equipment to the power inlet.
7. Place the power cord such a way that people can not step on it. Do not place anything over the power cord.
8. Always Unplug the Power Cord before inserting any add-on card or module.
9. All cautions and warnings on the equipment should be noted.
10. Never pour any liquid into the opening that could damage or cause electrical shock.
11. If any of the following situations arises, get the equipment checked by a service personnel:
 - The power cord or plug is damaged
 - Liquid has penetrated into the equipment
 - The equipment has been exposed to moisture
 - The equipment has not work well or you can not get it work according to User's Manual.
 - The equipment has dropped and damaged
 - If the equipment has obvious sign of breakage
12. **DO NOT LEAVE THIS EQUIPMENT IN AN ENVIRONMENT UNCONDITIONED, STORAGE TEMPERATURE ABOVE 60°C (140°F), IT MAY DAMAGE THE EQUIPMENT.**



CAUTION: Danger of explosion if battery is incorrectly replaced. Replace only with the same or equivalent type recommended by the manufacturer.

CONTENTS

Chapter 1. Introduction	1-1
Mainboard Specification	1-2
Mainboard Layout	1-4
Quick Components Guide	1-6
Key Features	1-7
MSI Special Features	1-8
D-LED™	1-8
Chapter 2. Hardware Setup	2-1
Central Processing Unit: CPU	2-2
CPU Installation Procedures	2-3
CPU Core Speed Derivation Procedure	2-4
Memory	2-5
Introduction to DDR SDRAM	2-5
DIMM Modules Combination	2-6
Installing DIMM Modules	2-6
Power Supply	2-7
ATX 20-Pin Power Supply	2-7
Back Panel	2-8
Mouse Connector	2-8
Keyboard Connector	2-9
USB Connectors	2-9
Parallel Port Connector	2-10
Serial Port Connectors: COM A & COM B	2-11
LAN (RJ-45) Jack (Pro266TD Master-LR)	2-11
Connectors	2-12
Floppy Disk Drive Connector: FDD1	2-12
Hard Disk Connectors: IDE1 & IDE2	2-13
IDE RAID Connectors: IDE3 & IDE4 (Pro266TD Master-LR)	2-14
Case Connector: JFP1	2-15

Power Saving LED Connector: JGL1	2-17
Chassis Intrusion Switch Connector: JCASE1	2-18
Power Saving Switch Connector: JGS1	2-18
Wake On Ring Connector: JMDM1	2-19
IrDA Infrared Module Connector: J14	2-19
Fan Power Connectors: CPUFN1/CPUFN2/SYSFN1/SYSFN2	2-20
Remote Power On/Off Switch Connector: JRMS1	2-21
TOP TECH III: JTECH1	2-21
USB Front Panel Connectors: USB2 & USB3	2-22
Wake On LAN Connector: JWOL1	2-23
Jumpers	2-24
Clear CMOS Jumper: JBAT1	2-24
Slots	2-25
AGP (Accelerated Graphics Port) Slot	2-25
PCI Slots	2-25
PCI Interrupt Request Routing	2-26
Chapter 3. AWARD® BIOS Setup	3-1
Entering Setup	3-2
Control Keys	3-2
Getting Help	3-3
The Main Menu	3-4
Standard CMOS Features	3-6
Advanced BIOS Features	3-9
Advanced Chipset Features	3-13
Integrated Peripherals	3-18
Power Management Setup	3-24
PnP/PCI Configurations	3-29
PC Health Status	3-31
Frequency/Voltage Control	3-33
Load Fail-Safe/Optimized Defaults	3-35

Set Supervisor/User Password	3-37
Save & Exit Setup	3-39
Exit Without Saving	3-40
Glossary	G-1

Introduction

1

Thank you for purchasing the Pro266TD Master series (MS-9105) ATX motherboard. Based on **Apollo Pro266T (VT8653+VT8233)** chipset, the motherboard supports SINGLE/DUAL Intel® Pentium® III processors (FC-PGA/FC-PGA2) and is designed for inexpensive workstation and entry-level server markets.

There are two models for Pro266TD Master series: **Pro266TD Master** and **Pro266TD Master-LR**. Pro266TD Master is the standard version. As for Pro266TD Master-IR, it integrates both LAN and IDE RAID technology on the board in addition to standard functions.

This chapter includes the following topics:

Mainboard Specification	1-2
Mainboard Layout	1-4
Quick Components Guide	1-6
Key Features	1-7
MSI Special Features	1-8

Chapter 1

Mainboard Specification

CPU

- Supports Single/Dual Intel® Pentium® III processors
- Supports Coppermine up to 1.1GHz @ 133MHz FSB
- Supports Tualatin up to 1.26GHz or higher @ 133MHz FSB



Note: Both Tualatin with 256K L2 cache and Tualatin with 512K L2 cache are able to be used on the motherboard. But Tualatin with 256K L2 cache can be used only when you install SINGLE CPU on the board.

Chipset

- VIA® VT8653 chipset (552 BGA)
 - 100/133MHz FSB settings
 - AGP 4x and PCI Advanced high performance memory controller
- VIA® VT8233 chipset (376 BGA)
 - High Bandwidth Vlink Client controller
 - Integrated Fast Ethernet LPC
 - Ultra DMA 33/66/100 master mode PCI EIDE controller
 - ACPI
- 266MB/sec high bandwidth North/South Bridge V-Link Bus

Clock Generator

- 100MHz/133MHz clocks are supported.

MainMemory

- Supports eight memory banks using four 184-pin DDR DIMM
- Supports up to 4GB ECC registered DDR200/266 SDRAM
- Supports 2.5v DDR SDRAM

Slots

- One (Accelerated Graphics Port) AGP slot
 - AGP specification compliant
 - Supports AGP 2.0 4x
- Five 32-bit Master PCI Bus slots
- Supports 3.3v/5v PCI bus Interface

On-Board IDE

- An IDE controller on the VIA® VT8233 chipset provides IDE HDD/CD-ROM with PIO, Bus Master and Ultra DMA 33/66/100 operation modes.
- Can connect up to four IDE devices

Promise 20265R On-Board (Pro266TD Master-LR only)

- Supports IDE RAID 0, 1
- Can connect up to four IDE devices

On-Board Peripherals

- On-Board Peripherals include:
 - 1 floppy port supports 2 FDDs with 360K, 720K, 1.2M, 1.44M and 2.88Mbytes.
 - 2 serial ports (COMA + COM B)
 - 1 parallel port supports SPP/EPP/ECP mode
 - 6 USB 1.1 ports (2 Rear Connectors/ 4 from USB Front Pin Headers)
 - 1 IrDA connector for SIR/CIR/ASKIR/HPSIR.

Network (Pro266TD Master-LR only)

- Intel 82559 Lan controller
 - Integrated IEEE 802.3 10BASE-T and 100BASE-TX compatible PHY
 - Wake-On-LAN and WFM 2.0 support
 - ACPI and PCI Power Management

BIOS

- The mainboard BIOS provides “Plug & Play” BIOS which detects the peripheral devices and expansion cards of the board automatically.
- The mainboard provides a Desktop Management Interface (DMI) function which records your mainboard specifications.

Dimension

- ATX Form Factor: 30.4cm x 25.4cm

Mounting

- 9 mounting holes, 6 Layers

Chapter 1

Mainboard Layout

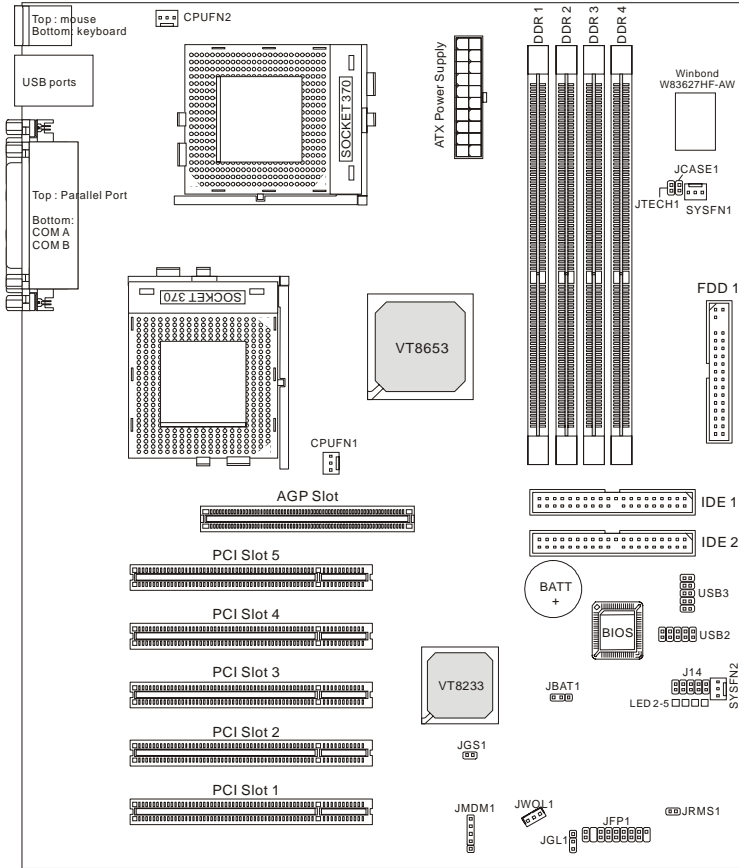

Pro266TD Master (MS-9105) ATX Mainboard

Introduction

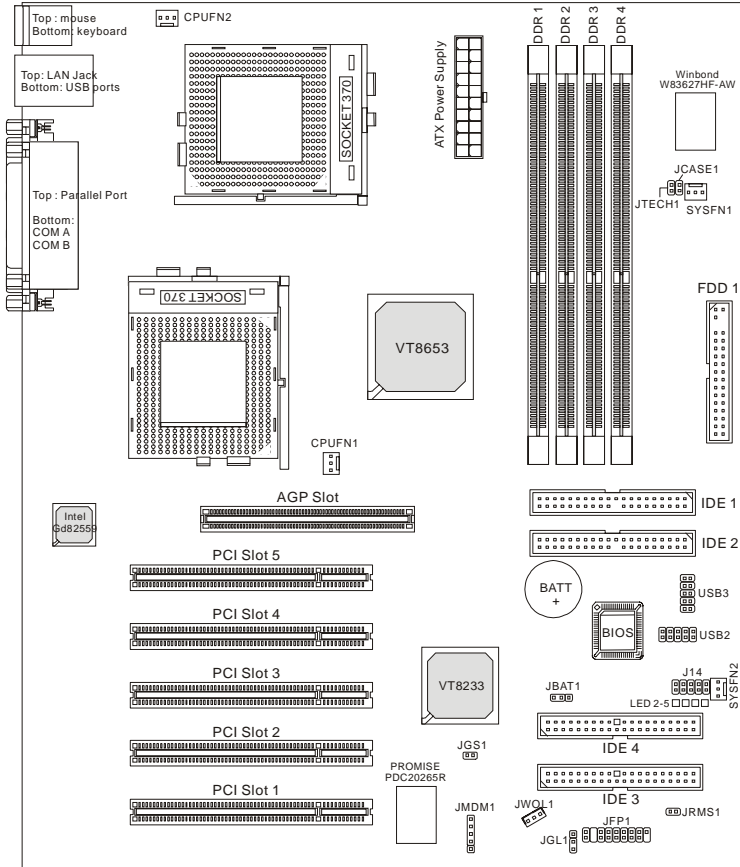

Pro266TD Master-LR (MS-9105) ATX Mainboard

Chapter 1

Quick Components Guide

Component	Function	Reference
DIMM1~4	Installing DDR DIMM modules	See p. 2-5~2-6
Socket 370	Installing Single/Dual CPUs	See p. 2-2~2-4
CPUFN1/2	Connecting to CPU FAN	See p. 2-20
SYSFN1/2	Connecting to SYSTEM FAN	See p. 2-20
ATX Power Supply	Installing power supply	See p. 2-7
IDE1& IDE2	Connecting to IDE hard disk drives	See p. 2-13
IDE3& IDE4	Connecting to IDE RAID hard disk drives	See p. 2-14
FDD1	Connecting to floppy disk drive	See p. 2-12
USB2/3	Connecting to USB interfaces	See p. 2-22
PCI Slot 1~5	Installing PCI expansion cards	See p. 2-25
AGP Slot	Installing AGP cards	See p. 2-25
JMDM1	Connecting to modem module	See p. 2-19
JWOL1	Connecting to LAN module	See p. 2-23
JBAT1	Clearing CMOS data	See p. 2-24
JFP1	Connecting to case	See p. 2-15
JGS1	Connecting to power saving switch	See p. 2-18
JGL1	Connecting to power saving LED	See p. 2-17
J14	Connecting to IR modules	See p. 2-19
JCASE1	Connecting to chassis intrusion switch	See p. 2-18
JRMS1	Connecting to power switch	See p. 2-21
JTECH1	Connecting to 20cm thermistor	See p. 2-21

Key Features

- ATX Form Factor
- CPU: Socket 370 for **Single/Dual** Intel® Pentium® III (FC-PGA/FC-PGA2) Processors
- Memory: 4 DDR DIMMs
- Slot: 1 AGP slot, 5 PCI slots
- I/O: 2 serial ports, 1 parallel port, 6 USB 1.1 ports, 1 floppy port, 1 IrDA connector, 2 IDE RAID connectors (Pro266TD Master-LR only), 1 LAN jack (Pro266TD Master-LR only)
- D-LED™ -- 4 Diagnostics LEDs embedded on the mainboard
- LAN Wake up Function
- Modem (External/Internal) Ring Wake up Function
- Promise 20265R Onboard with support for IDE RAID 0, 1 (Pro266TD Master-LR only)

Chapter 1

MSI Special Features

The MSI special features are designed by MSI R&D which are only available in MSI mainboards. The mainboard is equipped with D-LED™.

D-LED™

The D-LED™ uses graphic signal display to help users understand their system. Four LEDs embedded on the mainboard provide up to 16 combinations of signals to debug the system. The 4 LEDs can debug all problems that fail the system, such as VGA, RAM or other failures. This special feature is very useful for the overclocking users. These users can use the feature to detect if there are any problems or failures. The definitions of LED signal combinations are listed below:

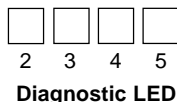

■ Red □ Green

D-LED	Description
2 3 4 5 ■ ■ ■ ■	System Power ON - The D-LED will hang here if the processor is damaged or not installed properly.
□ ■ ■ ■	Early Chipset Initialization
■ □ ■ ■	Memory Detection Test - Testing onboard memory size. The D-LED will hang if the memory module is damaged or not installed properly.
□ □ ■ ■	Decompressing BIOS image to RAM for fast booting.
■ ■ □ ■	Initializing Keyboard Controller.
□ ■ □ ■	Testing VGA BIOS - This will start writing VGA sign-on message to the screen.

Introduction

<input checked="" type="checkbox"/> <input type="checkbox"/> <input type="checkbox"/> <input checked="" type="checkbox"/>	<p>Processor Initialization</p> <p>- This will show information regarding the processor (like brand name, system bus, etc...)</p>
<input type="checkbox"/> <input type="checkbox"/> <input type="checkbox"/> <input checked="" type="checkbox"/>	<p>Testing RTC (Real Time Clock)</p>
<input checked="" type="checkbox"/> <input checked="" type="checkbox"/> <input checked="" type="checkbox"/> <input type="checkbox"/>	<p>Initializing Video Interface</p> <p>- This will start detecting CPU clock, checking type of video onboard. Then, detect and initialize the video adapter.</p>
<input type="checkbox"/> <input checked="" type="checkbox"/> <input checked="" type="checkbox"/> <input type="checkbox"/>	<p>BIOS Sign On</p> <p>- This will start showing information about logo, processor brand name, etc....</p>
<input checked="" type="checkbox"/> <input type="checkbox"/> <input checked="" type="checkbox"/> <input type="checkbox"/>	<p>Testing Base and Extended Memory</p> <p>- Testing base memory from 240K to 640K and extended memory above 1MB using various patterns.</p>
<input type="checkbox"/> <input type="checkbox"/> <input checked="" type="checkbox"/> <input type="checkbox"/>	<p>Assign Resources to all ISA.</p>
<input checked="" type="checkbox"/> <input checked="" type="checkbox"/> <input type="checkbox"/> <input type="checkbox"/>	<p>Initializing Hard Drive Controller</p> <p>- This will initialize IDE drive and controller.</p>
<input type="checkbox"/> <input checked="" type="checkbox"/> <input type="checkbox"/> <input type="checkbox"/>	<p>Initializing Floppy Drive Controller</p> <p>- This will initializing Floppy Drive and controller.</p>
<input checked="" type="checkbox"/> <input type="checkbox"/> <input type="checkbox"/> <input type="checkbox"/>	<p>Boot Attempt</p> <p>- This will set low stack and boot via INT 19h.</p>
<input type="checkbox"/> <input type="checkbox"/> <input type="checkbox"/> <input type="checkbox"/>	<p>Operating System Booting</p>

Hardware Setup

2

This chapter provides you with the information about hardware setup procedures. While doing the installation, be careful in holding the components and follow the installation procedures. For some components, if you install in the wrong orientation, the components will not work properly.

Use a grounded wrist strap before handling computer components. Static electricity may damage the components.

This chapter contains the following topics:

Central Processing Unit (CPU)	2-2
Memory	2-5
Power Supply	2-7
Back Panel	2-8
Connectors	2-12
Jumpers	2-24
Slots	2-25

Chapter 2

Central Processing Unit: CPU

The mainboard supports **Single/Dual Intel® Pentium III** processors. The mainboard uses two CPU sockets called Socket 370 for easy CPU installation. You can install **SINGLE** or **DUAL** CPUs on the board to meet your own needs. Keep the following points in mind before installing CPU(s):

- If **SINGLE** CPU is intended, always install the CPU on the **CPU1** socket.

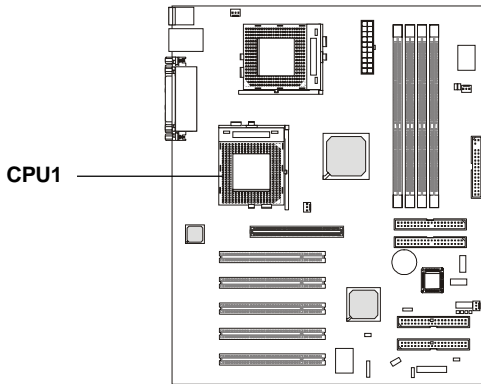

- To install **DUAL** CPUs on the board, you must use **the same type of CPUs running at the same FSB frequency**.

When you are installing the CPU, **make sure the CPU has a Heat Sink and a cooling fan attached on the top to prevent overheating**. If you do not find the Heat Sink and cooling fan, contact your dealer to purchase and install them before turning on the computer.



Note: Both Tualatin with 256K L2 cache and Tualatin with 512K L2 cache are able to be used on the motherboard. But **Tualatin with 256K L2 cache can be used only when you install SINGLE CPU on the board.**

CPU Installation Procedures

1. Pull the lever sideways away from the socket. Then, raise the lever up to a 90-degree angle.
2. Look for the gold arrow. The gold arrow should point towards the end of lever. The CPU will only fit in the correct orientation.
3. Hold the CPU down firmly, and then close the lever to complete the installation.

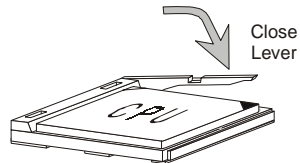
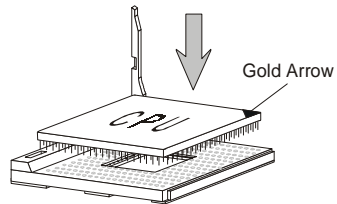
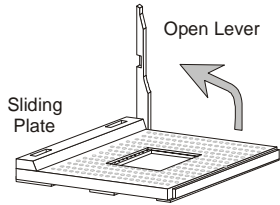

WARNING!

Overheating will seriously damage the CPU and system, always make sure the cooling fan can work properly to protect the CPU from overheating.

Chapter 2

CPU Core Speed Derivation Procedure

If	CPU Clock	=	100MHz
	Core/Bus ratio	=	7
then	CPU core speed	=	Host Clock x Core/Bus ratio
		=	100MHz x 7
		=	700MHz



Overclocking

WARNING! *This motherboard is designed to support overclocking. However, please make sure your components are able to tolerate such abnormal setting, while doing overclocking. Any attempt to operate beyond product specifications is not recommended. **We do not guarantee the damages or risks caused by inadequate operation or beyond product specifications.***

Memory

The mainboard provides 4 sockets for 184-pin DDR DIMM (Double In-Line Memory Module) modules and supports a maximum memory size of 4GB.

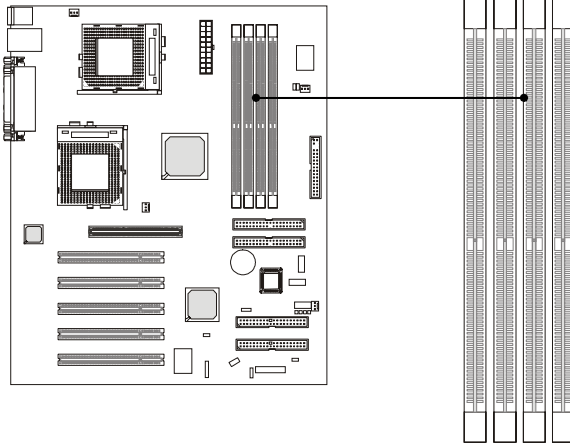

**DDR DIMM Slots
(DIMM 1~4)**

Introduction to DDR SDRAM

You can install PC1600/PC2100 DDR SDRAM modules on the DDR DIMM slots (DIMM 1~4).

DDR (Double Data Rate) SDRAM is similar to conventional SDRAM, but doubles the rate by transferring data twice per cycle. It transfers data on both the rising and falling edges of the clock. Conventional SDRAM only uses the rising edge of the clock to transfer data. Therefore, conventional SDRAM is called SDR (Single Data Rate) SDRAM.

DDR SDRAM uses 2.5 volts as opposed to 3.3 volts used in SDR SDRAM, and requires 184-pin DIMM modules rather than 168-pin DIMM modules used by SDR SDRAM. DDR SDRAM is also known as SDRAM-II, DDR DRAM and DSDRAM (Double-Speed DRAM).

Two types of DDR are available at the time of writing: PC1600 & PC2100. PC1600 DDR SDRAM running at 100MHz will produce about 1.6GB/s memory bandwidth. PC2100 running at 133MHz will produce 2.1GB/s memory bandwidth. High memory bandwidth makes DDR an ideal solution for high performance PC, workstations and servers.

Chapter 2

DIMM Modules Combination

At least one DIMM module should be installed on the motherboard. Memory modules can be installed on the slots in any order. The single-/double-sided memory modules that each DIMM slot supports are listed as below:

Socket	Memory Module	Total Memory
DIMM 1 (Bank0 & Bank1)	S/D	64MB ~ 1GB
DIMM 2 (Bank2 & Bank3)	S/D	64MB ~ 1GB
DIMM 3 (Bank4 & Bank5)	S/D	64MB ~ 1GB
DIMM 4 (Bank6 & Bank7)	S/D	64MB ~ 1GB
Maximum System Memory Supported		64MB ~ 4GB

S: Single Side

D: Double Side

Installing DIMM Modules

1. The DDR DIMM has only one notch on the center of module. The module will only fit in the right orientation.



Front Side



Rear Side

2. Insert the DIMM memory module vertically into the DIMM slot. Then push it in.

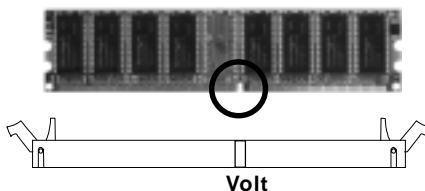

3. The plastic clip at each side of the DIMM slot will automatically close.

Power Supply

The mainboard supports ATX power supply for the power system. Before inserting the power supply connector, always make sure that all components are installed properly to ensure that no damage will be caused.

ATX 20-Pin Power Supply

This connector allows you to connect to an ATX power supply. To connect to the ATX power supply, make sure the plug of the power supply is inserted in the proper orientation and the pins are aligned. Then push down the power supply firmly into the connector.

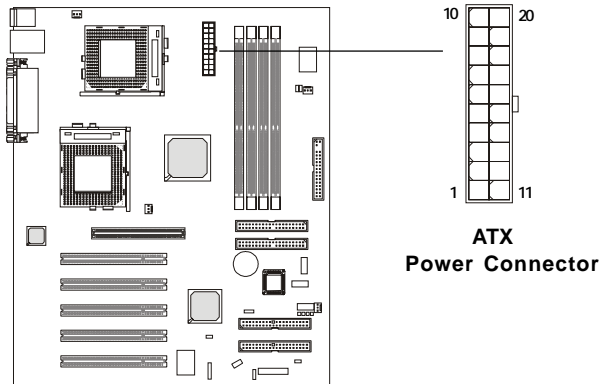

PIN	SIGNAL	PIN	SIGNAL
1	3.3V	11	3.3V
2	3.3V	12	-12V
3	GND	13	GND
4	5V	14	PS_ON
5	GND	15	GND
6	5V	16	GND
7	GND	17	GND
8	PW_OK	18	-5V
9	5V_SB	19	5V
10	12V	20	5V

Chapter 2

Back Panel

The Back Panel provides the following connectors:

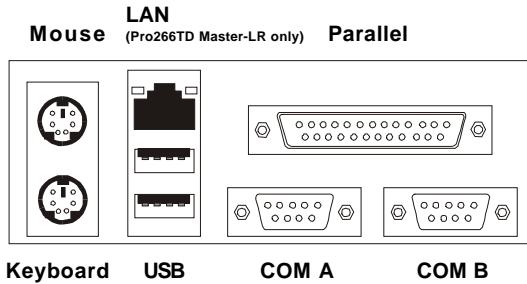

Mouse Connector

The mainboard provides a standard PS/2[®] mouse mini DIN connector for attaching a PS/2[®] mouse. You can plug a PS/2[®] mouse directly into this connector.

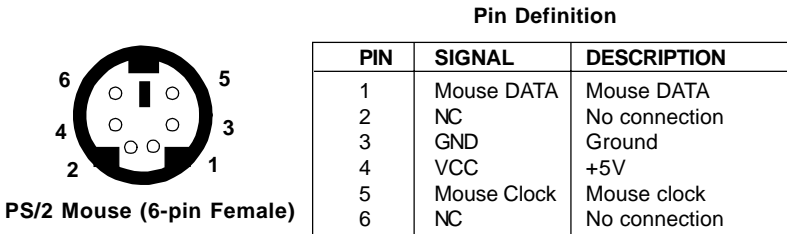

Keyboard Connector

The mainboard provides a standard PS/2® keyboard mini DIN connector for attaching a PS/2® keyboard. You can plug a PS/2® keyboard directly into this connector.

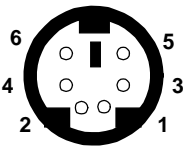

PS/2 Keyboard (6-pin Female)

Pin Definition

PIN	SIGNAL	DESCRIPTION
1	Keyboard DATA	Keyboard DATA
2	NC	No connection
3	GND	Ground
4	VCC	+5V
5	Keyboard Clock	Keyboard clock
6	NC	No connection

USB Connectors

The mainboard provides a UHCI (Universal Host Controller Interface) Universal Serial Bus root for attaching USB devices such as keyboard, mouse or other USB-compatible devices. You can plug the USB device directly into this connector.

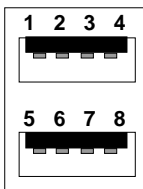

USB Ports

USB Port Description

PIN	SIGNAL	DESCRIPTION
1	VCC	+5V
2	-Data 0	Negative Data Channel 0
3	+Data0	Positive Data Channel 0
4	GND	Ground
5	VCC	+5V
6	-Data 1	Negative Data Channel 1
7	+Data 1	Positive Data Channel 1
8	GND	Ground

Chapter 2

Parallel Port Connector

The mainboard provides a 25-pin female centronic connector for LPT. A parallel port is a standard printer port that supports Enhanced Parallel Port (EPP) and Extended Capabilities Parallel Port (ECP) mode.

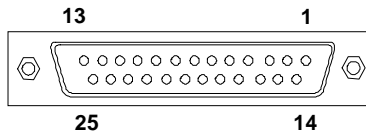

Pin Definition

PIN	SIGNAL	DESCRIPTION
1	STROBE	Strobe
2	DATA0	Data0
3	DATA1	Data1
4	DATA2	Data2
5	DATA3	Data3
6	DATA4	Data4
7	DATA5	Data5
8	DATA6	Data6
9	DATA7	Data7
10	ACK#	Acknowledge
11	BUSY	Busy
12	FE	Paper End
13	SELECT	Select
14	AUTOFEED#	Automatic Feed
15	ERR#	Error
16	INIT#	Initialize Printer
17	SLIN#	Select In
18	GND	Ground
19	GND	Ground
20	GND	Ground
21	GND	Ground
22	GND	Ground
23	GND	Ground
24	GND	Ground
25	GND	Ground

Serial Port Connectors: COM A & COM B

The mainboard has two 9-pin male DIN connectors for serial port COM A and COM B. You can attach a serial mouse or other serial devices.

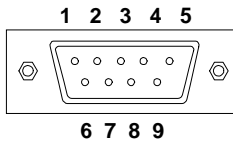

9-Pin Male DIN Connectors

Pin Definition

PIN	SIGNAL	DESCRIPTION
1	DCD	Data Carry Detect
2	SIN	Serial In or Receive Data
3	SOUT	Serial Out or Transmit Data
4	DTR	Data Terminal Ready)
5	GND	Ground
6	DSR	Data Set Ready
7	RTS	Request To Send
8	CTS	Clear To Send
9	RI	Ring Indicate

LAN (RJ-45) Jack (Pro266TD Master-LR)

The mainboard provides one standard RJ-45 jack for connection to Local Area Network (LAN). You can connect a network cable to the LAN jack.



LAN RJ-45 Jack

Pin Definition

PIN	SIGNAL	DESCRIPTION
1	TDP	Transmit Differential Pair
2	TDN	Transmit Differential Pair
3	RDP	Receive Differential Pair
4	NC	Not Used
5	NC	Not Used
6	RDN	Receive Differential Pair
7	NC	Not Used
8	NC	Not Used

Chapter 2

Connectors

The mainboard provides connectors to connect to FDD, IDE HDD, case, modem, LAN, USB Ports, IR module and CPU/System FAN.

Floppy Disk Drive Connector: FDD1

The mainboard provides a standard floppy disk drive connector that supports 360K, 720K, 1.2M, 1.44M and 2.88M floppy disk types.

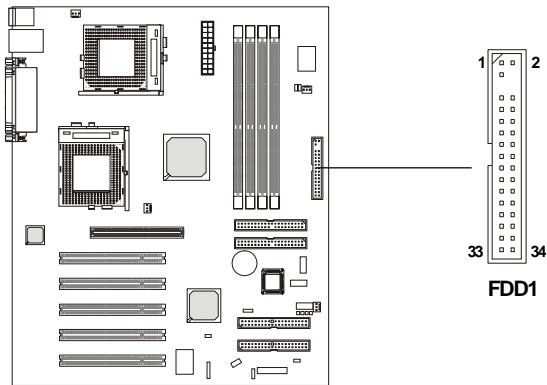

Hard Disk Connectors: IDE1 & IDE2

The mainboard uses an IDE controller on the VIA® VT8233 chipset that provides PIO mode 0-4, Bus Master, and Ultra DMA 33/66/100 modes. It has two HDD connectors IDE1 (Primary) and IDE2 (Secondary). You can connect up to four hard disk drives, CD-ROM or 120MB Floppy to IDE1 and IDE2.

IDE1 (Primary IDE Connector)

- The first hard disk drive should always be connected to IDE1. You can connect a Master and a Slave drive to IDE1.

IDE2 (Secondary IDE Connector)

- You can connect a Master and a Slave drive to IDE2.

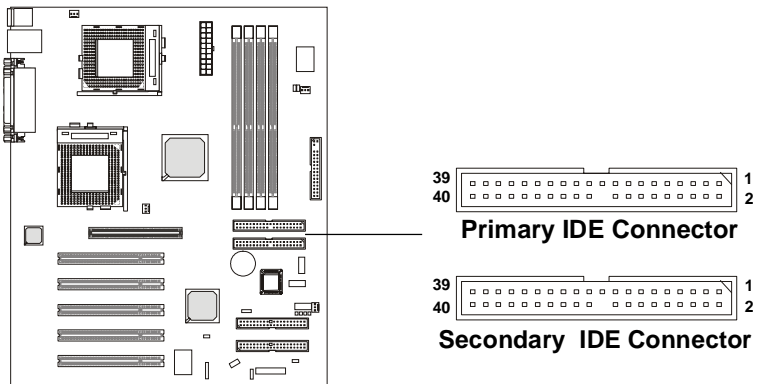

TIP

If you install two hard disks on cable, you must configure the second drive to Slave mode by setting its jumper. Refer to the hard disk documentation supplied by hard disk vendors for jumper setting instructions.

Chapter 2

IDE RAID Connectors: IDE3 & IDE4 (Pro266TD Master-LR)

The mainboard offers a low-cost RAID (Redundant Array of Independent Disks) solution by integrating two IDE RAID connectors that support PIO mode 0-4, Bus Master, and Ultra DMA 33/66/100 modes. The IDE RAID connectors allow you to connect Ultra ATA/DMA hard disks and use RAID technology for high performance, data security and fault tolerance. The connectors support RAID 0 (striping) and RAID 1 (mirroring).

IDE RAID Connectors

- You can connect a Master and a Slave drive to each IDE RAID connector.
 - The two connectors support **hard disk drives** only.
 - **For more information on IDE RAID, please refer to IDE RAID Manual.**
- (Please note only two of the installed hard disk drives will adopt RAID function, and usually they are Master drives.)

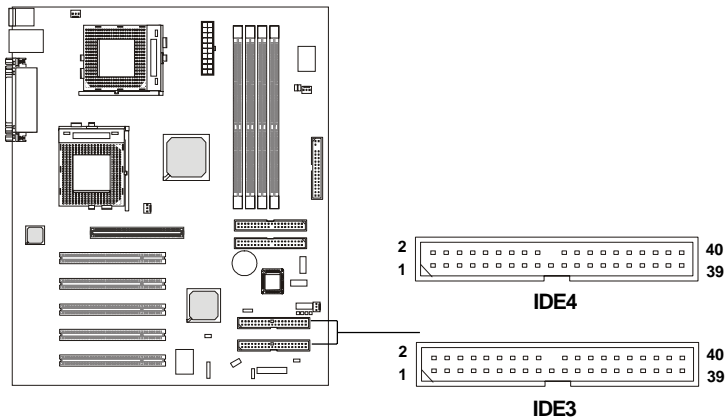

TIP

If you install two hard disks on cable, you must configure the second drive to Slave mode by setting its jumper. Refer to the hard disk documentation supplied by hard disk vendors for jumper setting instructions.

Case Connector: JFP1

The case connector block JFP1 allows you to connect to the Power Switch, Reset Switch, Speaker, Power LED, Keylock and HDD LED on the case.

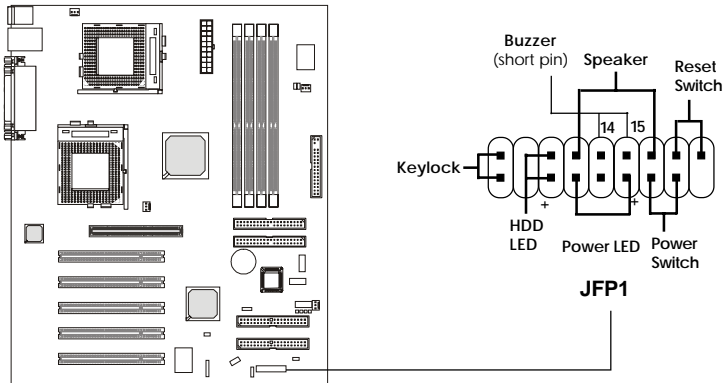

Power Switch

Connect to a 2-pin push button switch. The switch has the same feature as JRMS1.

Reset Switch

Reset switch is used to reboot the system rather than turning the power ON/OFF. Avoid rebooting while the HDD is working. You can connect the Reset switch from the system case to this pin.

PowerLED

The Power LED is lit while the system power is on.

Speaker

Speaker from the system case is connected to this pin.

If on-board Buzzer is available, then:

Short pin 14-15: On-board Buzzer Enabled.

Open pin 14-15: On-board Buzzer Disabled.

Chapter 2

HDDLED

HDD LED shows the activity of a hard disk drive connected to the IDE1, IDE2, IDE3 or IDE4 connector. Avoid turning the power off while the HDD is working. You can connect the HDD LED from the system case to this pin.

Keylock

Keylock allows you to disable the keyboard for security purpose. You can connect the keylock to this connector.

Power Saving LED Connector: JGL1

JGL1 is connected to a power saving LED. There are three types of LED that you can use: 3-pin/2-pin dual color or 2-pin single color LED. If connected to a dual color LED, the LED light is green when system is turned on, and turns to orange color while entering the suspend/sleep state. For the single color LED, the LED is lit when system is on, and blinks during the suspend/sleep state.

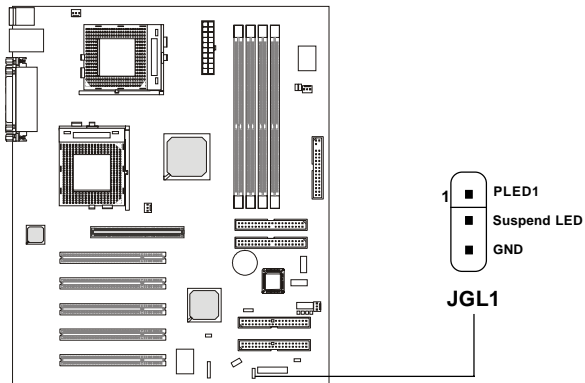

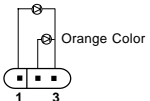
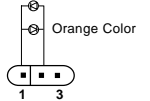
3-Pin LED	2-Pin LED
<p data-bbox="370 1107 449 1122">Green Color</p> <p data-bbox="423 1154 512 1169">Orange Color</p> 	<p data-bbox="642 1107 721 1122">Green Color</p> <p data-bbox="695 1154 785 1169">Orange Color</p> 
<p data-bbox="318 1248 535 1271">Green: Full-on Mode</p> <p data-bbox="318 1279 542 1303">Orange: Sleep Mode</p>	<p data-bbox="624 1248 736 1271">Dual Color</p>

Chapter 2

Chassis Intrusion Switch Connector: JCASE1

This connector is connected to a 2-pin chassis switch. If the chassis is opened, the switch will be short. The system will record this status and show a warning message on the screen. To clear the warning, you must enter the BIOS utility and clear the record.

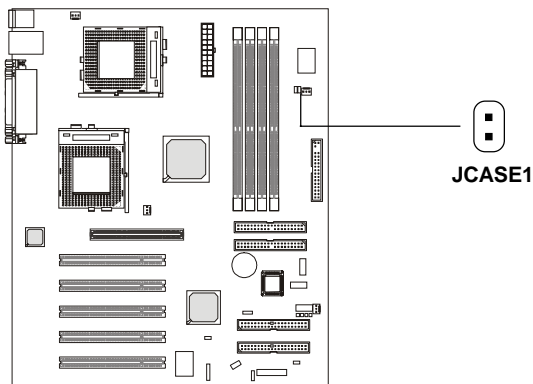

Power Saving Switch Connector: JGS1

Attach a power saving switch to this connector. Pressing the switch once will have the system enter the sleep/suspend state. Press any key to wake up the system.

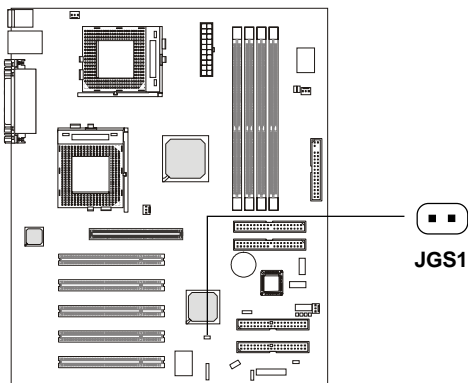

Wake On Ring Connector: JMDM1

This connector allows you to connect to a modem card with Wake On Ring function. The connector will power up the system when a signal is received through the modem card.

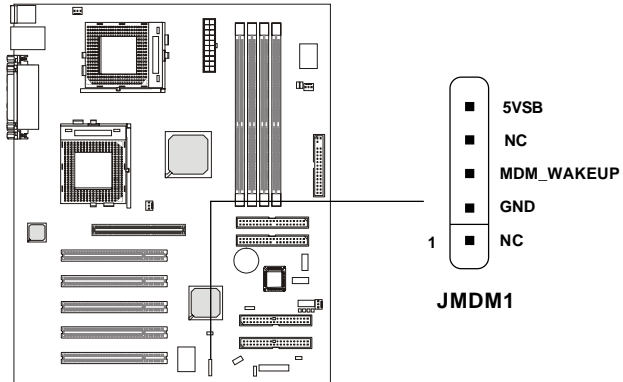

Note: Modem wake-up signal is active “low”.

IrDA Infrared Module Connector: J14

This connector allows you to connect to an IrDA Infrared module. You must configure the setting through the BIOS setup to use the IR function.

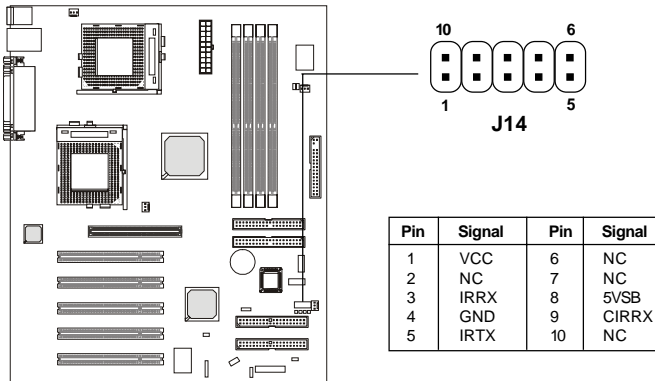

Chapter 2

Fan Power Connectors: CPUFN1/CPUFN2/SYSFN1/SYSFN2

The CPUFN1/CPUFN2 (processor fans) and SYSFN1/SYSFN2 (system fans) support system cooling fan with +12V. It supports three-pin head connector. When connecting the wire to the connectors, always take note that the red wire is the positive and should be connected to the +12V, the black wire is Ground and should be connected to GND. If the mainboard has a System Hardware Monitor chipset on-board, you must use a specially designed fan with speed sensor to take advantage of the CPU fan control.

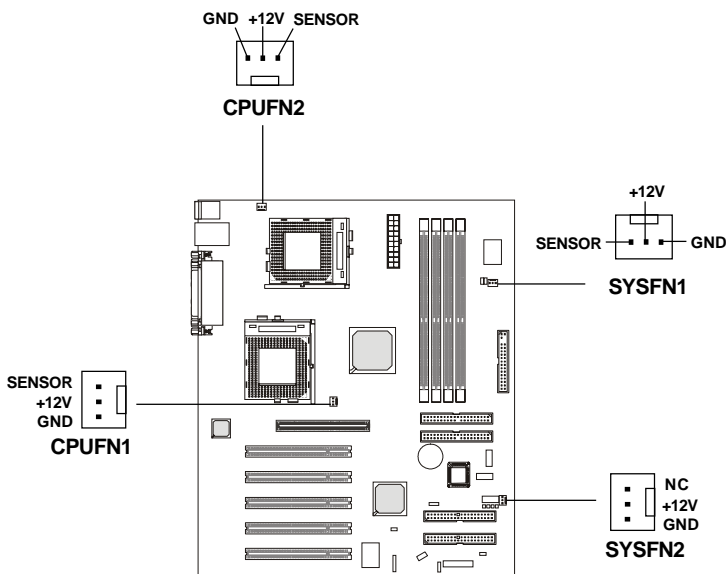

Note:

1. Always consult the vendor for proper CPU cooling fan.
2. CPU Fan supports the fan control. You can install the PC Alert utility that will automatically control the CPU Fan speed according to the actual CPU temperature.

Remote Power On/Off Switch Connector: JRMS1

Connect to a 2-pin push button switch. When OFF, pressing the button can turn the system on. When ON, pressing the button once will make the system enter the sleep/suspend state. If the button is pressed for more than four seconds, the system will be turned off. To change the setup, go to the BIOS Power Management Setup.

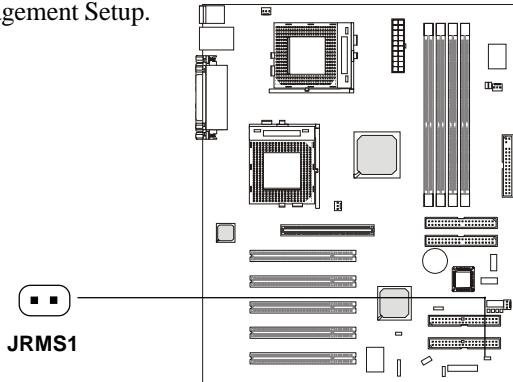

TOP TECH III: JTECH1

This is used to detect the AGP card temperature. The 2-pin connector can be connected to a 20cm thermistor to monitor the AGP thermal status.

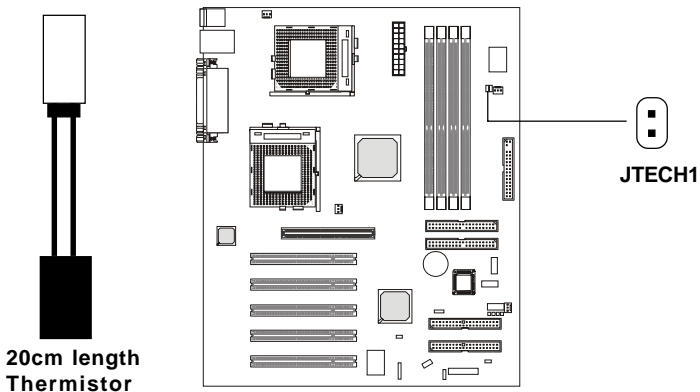

Chapter 2

USB Front Panel Connectors: USB2 & USB3

The mainboard provides two Front USB (Universal Serial Bus) pin headers that allow you to connect optional USB ports for Front Panel.

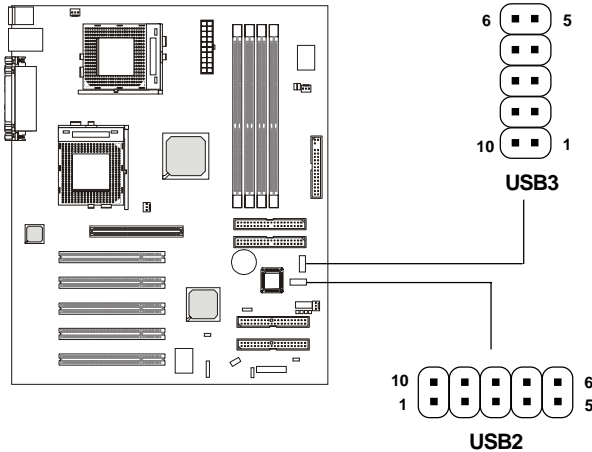

USB2 Pin Definition

Pin	Description	Pin	Description
1	VCC	10	GND
2	USB2-	9	GND
3	USB2+	8	USB3+
4	GND	7	USB3-
5	GND	6	VCC

USB3 Pin Definition

Pin	Description	Pin	Description
1	VCC	10	GND
2	USB4-	9	GND
3	USB4+	8	USB5+
4	GND	7	USB5-
5	GND	6	VCC

Wake On LAN Connector: JWOL1

This connector allows you to connect to a LAN card with Wake On LAN function. You can wake up the computer via remote control through a local area network.

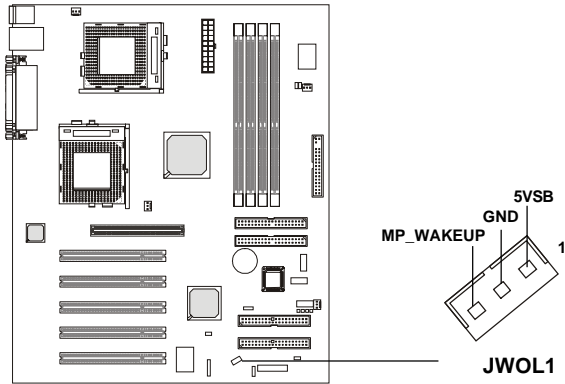

Chapter 2

Jumpers

The motherboard provides one jumper for you to set the computer's function. This section will explain how to change your motherboard's function through the use of the jumper.

Clear CMOS Jumper: JBAT1

There is a CMOS RAM on board that has a power supply from external battery to keep the data of system configuration. With the CMOS RAM, the system can automatically boot OS every time it is turned on. That battery has long life time for at least 5 years. If you want to clear the system configuration, use the JBAT1 (Clear CMOS Jumper) to clear data. Follow the instructions below to clear the data:

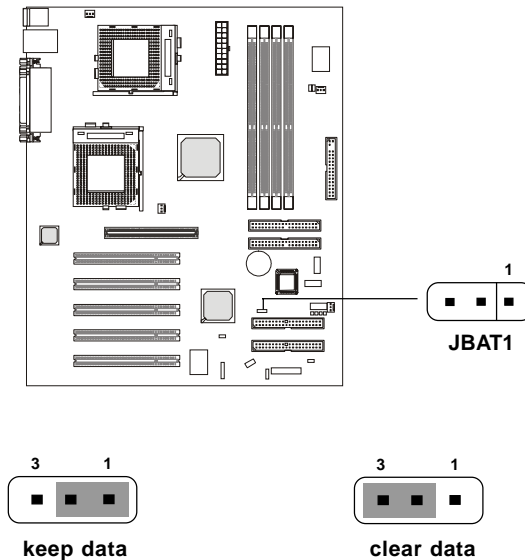

WARNING!

You can clear CMOS by shorting 2-3 pin while AC power is removed. Then return to 1-2 pin position. Avoid clearing the CMOS while the system is on; it will damage the mainboard.

Slots

The motherboard provides five 32-bit Master PCI Bus Slots and one AGP slot.

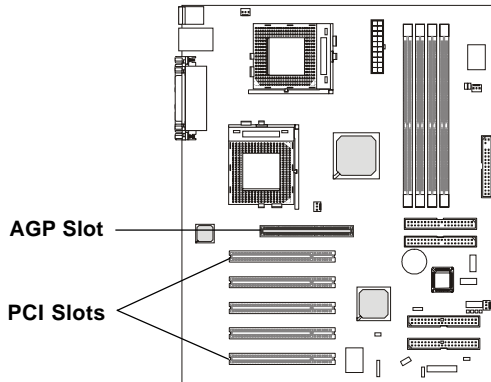

AGP (Accelerated Graphics Port) Slot

The AGP slot allows you to insert the AGP graphics card. AGP is an interface specification designed for the throughput demands of 3D graphics. It introduces a 66MHz, 32-bit channel for the graphics controller to directly access main memory and provides three levels of throughputs: 1x (266Mbps), 2x (533Mbps) and 4x (1.07Gbps). **The mainboard supports AGP 4x only.**

PCI Slots

Five PCI slots allow you to insert the expansion cards to meet your needs. When adding or removing expansion cards, make sure that you unplug the power supply first. Meanwhile, read the documentation for the expansion card to make any necessary hardware or software settings for the expansion card, such as jumpers, switches or BIOS configuration.

Chapter 2

PCI Interrupt Request Routing

The IRQ, abbreviation of interrupt request line and pronounced I-R-Q, are hardware lines over which devices can send interrupt signals to the microprocessor.

The “AGP/PCI/Promise RAID/LAN” IRQ pins are typically connected to the PCI bus INTA#-INTD# pins as follows:

	Order 1	Order 2	Order 3	Order 4
AGP	INT A#	INT B#		
PCI Slot 1	INT D#	INT A#	INT B#	INT C#
PCI Slot 2	INT C#	INT D#	INT A#	INT B#
PCI Slot 3	INT C#	INT D#	INT A#	INT B#
PCI Slot 4	INT A#	INT B#	INT C#	INT D#
PCI Slot 5	INT D#	INT A#	INT B#	INT C#
Promise RAID	INT B#			
LAN	INT A#			

AGP & PCI Slot 4 & LAN shared.

PCI Slot 1 & PCI Slot 5 shared.

PCI Slot 2 & PCI Slot 3 shared.

PCI Slot 1~5: Bus Master

AWARD® BIOS Setup

3

The mainboard uses AWARD® BIOS ROM that provides a Setup utility for users to modify the basic system configuration. The information is stored in a battery-backed CMOS RAM so it retains the Setup information when the power is turned off.

The chapter contains the following topics:

Entering Setup	3-2
Control Keys	3-2
Getting Help	3-3
The Main Menu	3-4
Standard CMOS Features	3-6
Advanced BIOS Features	3-9
Advanced Chipset Features	3-13
Integrated Peripherals	3-18
Power Management Setup	3-24
PnP/PCI Configurations	3-29
PC Health Status	3-31
Frequency/Voltage Control	3-33
Load Fail-Safe/Optimized Defaults	3-35
Set Supervisor/User Password	3-37
Save & Exit Setup	3-39
Exit Without Saving	3-40

Chapter 3

Entering Setup

Power on the computer and the system will start POST (Power On Self Test) process. When the message below appears on the screen, press key to enter Setup.

Press Del to Enter SETUP

If the message disappears before you respond and you still wish to enter Setup, restart the system by turning it OFF and On or pressing the RESET button. You may also restart the system by simultaneously pressing <Ctrl>, <Alt>, and <Delete> keys.

Control Keys

<↑>	Move to the previous item
<↓>	Move to the next item
<←>	Move to the item in the left hand
<→>	Move to the item in the right hand
<Enter>	Select the item
<Esc>	Jumps to the Exit menu or returns to the main menu from a submenu
<+/PU>	Increase the numeric value or make changes
<-/PD>	Decrease the numeric value or make changes
<F1>	General help, only for Status Page Setup Menu and Option Page Setup Menu
<F5>	Restore the previous CMOS value from CMOS, only for Option Page Setup Menu
<F6>	Load the default CMOS value from Fail-Safe default table, only for Option Page Setup Menu
<F7>	Load Optimized defaults
<F10>	Save all the CMOS changes and exit

Getting Help

After entering the Setup utility, the first screen you see is the Main Menu.

Main Menu

The main menu displays the setup categories the BIOS supplies. You can use the arrow keys (↑↓) to select the item. The on-line description for the selected setup category is displayed on the bottom of the screen.

Sub-Menu

If you find a right pointer symbol appears to the left of certain fields (as shown in the right view), that means a sub-menu containing additional options for the field can be launched from this field. To enter the sub-menu, highlight the field and press <Enter>. Then you can use control keys to move between and change the settings of the sub-menu. To return to the main menu, press <Esc>.

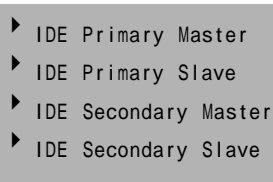

General Help <F1>

The BIOS setup program provides a General Help screen. You can call up this screen from any menu by simply pressing <F1>. The Help screen lists the appropriate keys to use and the possible selections for the highlighted item. Press <Esc> to exit the Help screen.

Chapter 3

The Main Menu

Once you enter AWARD® BIOS CMOS Setup Utility, the Main Menu will appear on the screen. The Main Menu displays twelve configurable functions and two exit choices. Use arrow keys to move among the items and press <Enter> to enter the sub-menu.

CMOS Setup Utility - Copyright(C) 1984-2001 Award Software

▶ Standard CMOS Features	▶ Frequency/Voltage Control
▶ Advanced BIOS Features	Load Fail-Safe Defaults
▶ Advanced Chipset Features	Load Optimized Defaults
▶ Integrated Peripherals	Set Supervisor Password
▶ Power Management Setup	Set User Password
▶ PnP/PCI Configurations	Save & Exit Setup
▶ PC Health Status	Exit Without Saving
ESC : Quit F9 : Menu in BIOS ↑↓←→ : Select Item	
F10 : Save & Exit Setup	
Time, Date, Hard Disk Type...	

Standard CMOS Features

Use this menu for basic system configurations, such as time, date etc.

Advanced BIOS Features

Use this menu to setup the items of Award® special enhanced features.

Advanced Chipset Features

Use this menu to change the values in the chipset registers and optimize your system's performance.

Integrated Peripherals

Use this menu to specify your settings for integrated peripherals.

Power Management Setup

Use this menu to specify your settings for power management.

PnP/PCI Configurations

This entry appears if your system supports PnP/PCI.

PC Health Status

This entry displays the current status of your PC.

Frequency/Voltage Control

Use this menu to specify your settings for frequency/voltage control.

Load Fail-Safe Defaults

Use this menu to load the BIOS default values for the minimal/stable performance of your PC.

Load Optimized Defaults

Use this menu to load the default factory settings for BIOS for optimal system performance.

Set Supervisor Password

Use this menu to set Supervisor Password.

Set User Password

Use this menu to set User Password.

Save & Exit Setup

Save changes to CMOS and exit setup.

Exit Without Saving

Abandon all changes and exit setup.

Chapter 3

Standard CMOS Features

The items inside Standard CMOS Features menu are divided into 13 categories. Each category includes none, one or more setup items. Use the arrow keys to highlight the item you want to modify and use the <PgUp> or <PgDn> keys to switch to the value you prefer.

CMOS Setup Utility - Copyright (C) 1984-2001 Award Software
Standard CMOS Features

Date (mm:dd:yy) Time (hh:mm:ss)	Fri, Aug 10 2001 00:00:00	Item Help
▶ IDE Primary Master ▶ IDE Primary Slave ▶ IDE Secondary Master ▶ IDE Secondary Slave		Menu Level ▶ Change the day, month, year and century
Drive A Drive B	1.44M, 3.5 in. None	
Video Halt On	EGA/VGA All, But Keyboard	
Base Memory Extended Memory Total Memory	640K 65472K 66112K	
↑↓←→:Move Enter:Select +/-/PU/PD:Value F10:Save ESC:Exit F1:General Help F5: Previous Values F6: Fail-Safe Defaults F7: Optimized Defaults		

Date

This allows you to set the system to the date that you want (usually the current date). The format is <day><month> <date> <year>.

- day** Day of the week, from Sun to Sat, determined by BIOS. Read-only.
- month** The month from Jan. through Dec.
- date** The date from 1 to 31 can be keyed by numeric function keys.
- year** The year can be adjusted by users.

Time

This allows you to set the system time that you want (usually the current time). The time format is <hour> <minute> <second>.

IDE Primary Master/Primary Slave/Secondary Master/Secondary Slave

Press PgUp/<+> or PgDn/<-> to select the hard disk drive type. The specification of hard disk drive will show up on the right hand according to your selection.

IDE Primary Master		Item Help
IDE HDD Auto-Detection	Press Enter	
IDE Primary Master Access Mode	Auto	Menu Level ▶ ▶
Capacity	15021MB	To auto-detect the HDD's size, head...on this channel
Cylinder	291024	
Head	16	
Precomp	0	
Landing Zone	29103	
Sector	63	

- Access Mode The settings are Auto, CHS, LBA and Large.
- Capacity The formatted size of the storage device.
- Cylinder Number of cylinders.
- Head Number of heads.
- Precomp Write precompensation cylinder.
- Landing Zone Cylinder location of the landing zone.
- Sector Number of sectors.

Drive A/B

This item allows you to set the type of floppy drives installed. Available options: *None, 360K, 5.25 in., 1.2M, 5.25 in., 720K, 3.5 in., 1.44M, 3.5 in. and 2.88M, 3.5 in..*

Video

The item sets the type of video adapter used for the primary monitor of the system . Available options: *EGA/VGA , CGA 40, CGA 80 and MONO.*

Chapter 3

Halt On

The item determines whether the system will stop if an error is detected at boot. Available options are:

<i>All Errors</i>	The system stops when any error is detected.
<i>No Errors</i>	The system doesn't stop for any detected error.
<i>All, But Keyboard</i>	The system doesn't stop for a keyboard error.
<i>All, But Diskette</i>	The system doesn't stop for a disk error.
<i>All, But Disk/Key</i>	The system doesn't stop for either a disk or a keyboard error.

Advanced BIOS Features

CMOS Setup Utility - Copyright (C) 1984-2001 Award Software
Advanced BIOS Features

Anti-Virus Protection	Disabled	Item Help
BIOS Flash Write Control	Disabled	
CPU Internal Cache	Enabled	Menu Level ▶ Allows you to choose the VIRUS warning feature for IDE Hard Disk boot sector protection. If this function is enabled and someone attempt to write data into this area, BIOS will show a warning message on screen and alarm beep
External Cache	Enabled	
CPU L2 Cache ECC Checking	Disabled	
Processor Number Feature	Enabled	
Quick Power On Self Test	Enabled	
Raid & SCSI Boot Order	Raid, SCSI	
First Boot Device	Floppy	
Second Boot Device	HDD-0	
Third Boot Device	LS120	
Boot Other Device	Enabled	
Swap Floppy Drive	Disabled	
Boot Up NumLock Status	On	
Gate A20 Option	Fast	
Security Option	Setup	
MPS Version Control For OS	1.4	
OS Select for DRAM > 64MB	Non-OS2	
↑↓←→:Move Enter:Select +/-/PU/PD:Value F10:Save ESC:Exit F1:General Help F5: Previous Values F6 :Fail-Safe Defaults F7 :Optimized Defaults		

Anti-Virus Protection

The item is to set the Virus Warning feature for IDE Hard Disk boot sector protection. If the function is enabled and any attempt to write data into this area is made, BIOS will display a warning message on the screen and beep. Settings: *Disabled* and *Enabled*.

BIOS Flash Write Control

The item is used to enable or disable the BIOS Flash Write Control. Select *Enabled* when performing BIOS update with the flash utility.

CPU Internal Cache

The item allows you to turn on or off CPU's internal (L1) cache. Settings: *Enabled* and *Disabled*.

External Cache

This allows you to turn on or off L2 (Level 2) cache memory for CPU. Settings: *Enabled* and *Disabled*.

Chapter 3

CPU L2 Cache ECC Checking

This allows you to enable or disable the ECC (Error-Correcting Code) feature for error detection and correction when data passes through L2 cache memory. Settings: *Enabled* and *Disabled*.

Processor Number Feature

This option is for Pentium® III processor only. When set to *Enabled*, this will check the CPU Serial number. Disable this option if you don't want the system to know the serial number.

Quick Power On Self Test

The option speeds up Power On Self Test (POST) after you power on the computer. When setting the item to *Enabled*, BIOS will shorten or skip some check items during POST. Settings: *Enabled* and *Disabled*.

Raid & SCSI Boot Order

The field allows you to determine the boot priority of the attached SCSI card and Promise IDE RAID device when **First, Second** or **Third Boot Device** is set to *SCSI*. Settings: *Raid, SCSI* and *SCSI, Raid*.

First/Second/Third Boot Device

The items allow you to set the sequence of boot devices where BIOS attempts to load the disk operating system. The settings are:

<i>Floppy</i>	The system will boot from floppy drive.
<i>LS120</i>	The system will boot from LS-120 drive.
<i>HDD-0</i>	The system will boot from the first HDD.
<i>SCSI</i>	The system will boot from the SCSI.
<i>CDROM</i>	The system will boot from the CD-ROM.
<i>HDD-1</i>	The system will boot from the second HDD.
<i>HDD-2</i>	The system will boot from the third HDD.
<i>HDD-3</i>	The system will boot from the fourth HDD.
<i>ZIP100/250</i>	The system will boot from ATAPI ZIP drive.
<i>LAN</i>	The system will boot from the Network drive.
<i>Disabled</i>	Disable this sequence.

Boot Other Device

Setting the option to *Enabled* allows the system to try to boot from other

device if the system fails to boot from the 1st/2nd/3rd boot device.

Swap Floppy Drive

Setting to *Enabled* will swap floppy drives A: and B:.

Boot Up NumLock Status

This item is to set the Num Lock status when the system is powered on. Setting to *On* will turn on the Num Lock key when the system is powered on. Setting to *Off* will allow end users to use the arrow keys on the numeric keypad. Settings: *On* and *Off*.

Gate A20 Option

This item is to set the Gate A20 status. A20 refers to the first 64KB of extended memory. When *Fast* is selected, the Gate A20 is controlled by Port92 or chipset specific method resulting in faster system performance. When *Normal* is selected, A20 is controlled by a keyboard controller or chipset hardware.

Security Option

This specifies the type of BIOS password protection that is implemented. Settings are described below:

Option	Description
Setup	The password prompt appears only when end users try to run Setup.
System	A password prompt appears every time when the computer is powered on or when end users try to run Setup.

MPS Version Control For OS

This field allows you to select which MPS (Multi-Processor Specification) version to be used for the operating system. The MPS is a specification by which PC manufacturers design Intel architecture systems with two or more processors. Most newer server operating systems support MPS 1.4, such as Noverll IntranetWare 4.1 or Microsoft Windows Server NT 4.0. To find out which version to use, consult the vendor of your operating system. Settings: *1.4* and *1.1*.

Chapter 3

OS Select for DRAM > 64MB

This allows you to run the OS/2[®] operating system with more than 64MB DRAM. When you choose *Non-OS2*, you cannot run the OS/2[®] operating system with DRAM larger than 64MB. But it is possible if you choose *OS2*.

Advanced Chipset Features

CMOS Setup Utility - Copyright (C) 1984-2001 Award Software
Advanced Chipset Features

<ul style="list-style-type: none"> ▶ DRAM Clock/Drive Control Press Enter ▶ AGP & P2P Bridge Control Press Enter ▶ CPU & PCI Bus Control Press Enter Memory Hole Disabled System BIOS Cacheable Disabled Memory Parity/ECC Check Disabled 	Item Help
	Menu Level ▶
↑↓→←:Move Enter:Select +/-/PU/PD:Value F10:Save ESC:Exit F1:General Help F5: Previous Values F6: Fail-Safe Defaults F7: Optimized Defaults	



Note: Change these settings only if you are familiar with the chipset.

DRAM Clock/Drive Control

Press <Enter> to enter the sub-menu, and you will see a sub-menu screen similar to the following:

DRAM Clock/Drive Control		Item Help
<ul style="list-style-type: none"> Current FSB Frequency 100MHz Current DRAM Frequency 100MHz DRAM Clock By SPD DRAM Timing By SPD x DRAM CAS Latency 2.5 x Bank Interleave Disabled 		Menu Level ▶ ▶

Chapter 3

Current FSB/DRAM Frequency

The fields are used to display current host bus (Front Side Bus)/DRAM clock frequency.

DRAM Clock

The chipset supports synchronous and asynchronous mode between host clock and DRAM clock frequency. Available settings are:

Host CLK: The DRAM clock will be equal to the Host clock.

HCLK-33M: The DRAM clock will be equal to the Host clock minus 33MHz. For example, if the Host clock is 133MHz, the DRAM clock will be 100MHz.

HCLK+33M: The DRAM clock will be equal to the Host clock plus 33MHz. For example, if the Host clock is 100MHz, the DRAM clock will 133MHz.

By SPD: DRAM clock frequency is determined based on the contents of SPD EEPROM on the DRAM module.

DRAM Timing

The field determines whether DRAM timing is configured by reading the contents of the SPD (Serial Presence Detect) EEPROM on the DRAM module. Selecting *By SPD* makes SDRAM CAS Latency and Bank Interleave automatically determined by BIOS according to the configurations on the SPD.

SDRAM CAS Latency

The field controls the timing delay before SDRAM starts a read command after receiving it. Settings: 2.5 and 2 (clock cycles). 2 increases system performance while 2.5 provides more stable system performance.

Bank Interleave

Select 2- or 4-Bank interleave for installed SDRAM. Settings: *2 Bank*, *4 Bank* and *Disabled*.

AGP & P2P Bridge Control

Press <Enter> to go to the sub-menu screen similar to the following.

AGP & P2P Bridge Control

AGP Aperture Size	64M	Item Help
AGP Mode	4X	
AGP Driving Control	Auto	Menu Level ▶▶
x AGP Driving Value	DA	
AGP Fast Write	Disabled	
AGP Master 1 WS Write	Disabled	
AGP Master 1 WS Read	Disabled	

AGP Aperture Size

Select the size of Accelerated Graphics Port (AGP) aperture. Aperture is a portion of PCI memory address range dedicated for graphics memory address space. Host cycles that hit the aperture range are forwarded to AGP without any translation. Settings: *4M, 8M, 16M, 32M, 64M, 128M* and *256M*.

AGP Mode

Select the appropriate AGP mode. Settings: *1X, 2X* and *4X*. Choose *4X* only if your AGP card supports the mode.

AGP Driving Control

The field is used to adjust AGP driving force. Selecting *Manual* allows you to type a AGP driving force in AGP Driving Value. It is strongly suggested to select *Auto* to avoid causing any system error.

AGP Driving Value

Specify the AGP driving value in the field.

AGP Fast Write

Use the field to enable or disable the AGP Fast Write feature. The Fast Write technology allows CPU to write directly into the graphics card without passing anything through system memory and improves 4X speed accordingly. Select *Enabled* only when your AGP card supports the feature.

Chapter 3

AGP Master 1 WS Write

When *Enabled*, writes to the AGP bus are executed with one wait state inserted.

AGP Master 1 WS Read

When *Enabled*, one wait state is inserted in the AGP read cycle.

CPU & PCI Bus Control

Press <Enter> and the following sub-menu screen will appear:

CPU & PCI Bus Control		Item Help
CPU to PCI Write Buffer	Enabled	Menu Level ▶ ▶
PCI Master 0 WS Write	Enabled	
PCI Delay Transaction	Disabled	

CPU to PCI Write Buffer

When *Enabled*, CPU can write up to four words of data to the PCI write buffer before CPU must wait for PCI bus cycle to finish. If *Disabled*, CPU must wait after each write cycle until PCI bus signals that it is ready to receive more data.

PCI Master 0 WS Write

When *Enabled*, writes to the PCI bus are executed with zero wait state.

PCIDelay Transaction

The chipset has an embedded 32-bit posted write buffer to support delay transaction cycles. Select *Enabled* to support compliance with PCI specification version 2.1.

Memory Hole

In order to improve performance, certain space in memory can be reserved

for ISA peripherals. This memory must be mapped into the memory space below 16MB. When this area is reserved, it cannot be cached. Settings: *15M-16M* and *Disabled*.

System BIOS Cacheable

System BIOS ROM at F0000h-FFFFFh is always copied to RAM for faster execution. Selecting *Enabled* allows the contents of F0000h RAM memory segment to be written to and read from cache memory, resulting in better system performance. However, if any program writes to this memory area, a system error may result. Settings: *Enabled* and *Disabled*.

Memory Parity/ECC Check

User can set the field to *Enabled* for memory checking if the type of DRAM installed in your system is Parity or ECC (Error-Correcting Code) DRAM.

Chapter 3

Integrated Peripherals

CMOS Setup Utility - Copyright (C) 1984-2001 Award Software
Integrated Peripherals

OnBoard Promise Control	Enabled	Item Help
OnBoard LAN Control	Enabled	
▶ VIA OnChip IDE Device	Press Enter	
▶ SuperIO Device	Press Enter	Menu Level ▶
Init Display First	PCI Slot	
OnChip USB Controller	All Enabled	
USB Keyboard Support	Enabled	
IDE HDD Block Mode	Enabled	
PWRON After PWR-Fail	Off	
Power Status Led	Single	

↑↓→←:Move Enter:Select +/-/PU/PD:Value F10:Save ESC:Exit F1:General Help
F5: Previous Values F6: Fail-Safe Defaults F7: Optimized Defaults

OnBoard Promise Control

The field allows you to enable or disable the onboard Promise IDE RAID controller if any. Settings: *Enabled* and *Disabled*.

OnBoard LAN Control

The field allows you to enable or disable the onboard LAN controller if any. Settings: *Enabled* and *Disabled*.

VIA OnChip IDE Device

Press <Enter> to go to the sub-menu screen similar to the following:

VIA OnChip IDE Device

OnChip IDE Channel0		Enabled	Item Help
OnChip IDE Channel1		Enabled	
IDE Prefetch Mode		Enabled	Menu Level ▶▶
Primary Master	PIO	Auto	
Primary Slave	PIO	Auto	
Secondary Master	PIO	Auto	
Secondary Slave	PIO	Auto	
Primary Master	UDMA	Auto	
Primary Slave	UDMA	Auto	
Secondary Master	UDMA	Auto	
Secondary Slave	UDMA	Auto	

OnChip IDE Channel0/1

The integrated peripheral controller contains an IDE interface with support for two IDE channels. Choose *Enabled* to activate each channel separately.

IDE Prefetch Mode

The onboard IDE drive interfaces support prefetching, for faster drive access. Set to *Disabled* if your primary and/or secondary add-in IDE interface does not support prefetching.

Primary/Secondary Master/Slave PIO

The four fields allow you to set a PIO (Programmed Input/Output) mode for each of the four IDE devices that the onboard IDE interface supports. Modes 0~4 provide increased performance. In *Auto* mode, BIOS automatically determines the best mode for each IDE device.

Primary/Secondary Master/Slave UDMA

Ultra DMA implementation is possible only if your IDE device supports it and your operating environment contains a DMA driver. If both your hard drive and software support Ultra DMA 33/66/100, select *Auto* to enable BIOS support.

SuperIO Device

Press <Enter> to enter the sub-menu screen similar to the following:

Chapter 3

SuperIO Device

		Item Help
POWER ON Function	BUTTON ONLY	
KB Power ON Password	Enter	
Hot Key Power ON	Ctrl-F1	
Onboard FDC Controller	Enabled	Menu Level ▶ ▶
Onboard Serial Port 1	3F8/IRQ4	
Onboard Serial Port 2	2F8/IRQ3	
UART Mode Select	Normal	
RxD, TxD Active	Hi, Lo	
IR Transmission Delay	Enabled	
UR2 Duplex Mode	Half	
Use IR Pins	IR-Rx2Tx2	
Onboard Parallel Port	378/IRQ7	
Parallel Port Mode	SPP	
EPP Mode Select	EPP1.7	
ECP Mode Use DMA	3	

POWER ON Function

This controls which part on the PS/2 mouse or keyboard can power on the system. Settings: *Password*, *Hot KEY*, *Mouse Left*, *Mouse Right*, *Any KEY*, *BUTTON ONLY* and *Keyboard 98*.

KB Power ON Password

If **POWER ON Function** is set to *Password*, then you can set a password in the field for PS/2 keyboard to power on the system.

Hot Key Power ON

If **POWER ON Function** is set to *Hot KEY*, then you can assign a hot key combination in the field for the PS/2 keyboard to power on the system. Settings: *Ctrl-F1* through *Ctrl-F12*.

Onboard FDC Controller

The field enables or disables the onboard Floppy controller. Select *Enabled* when you have a floppy disk drive installed and want to use it.

Onboard Serial Port 1/2

The items specify the base I/O port address and IRQ for the onboard Serial Port 1 (COM A)/Serial Port 2 (COM B). Selecting *Auto* allows BIOS to automatically determine the correct base I/O port address. Settings: *Disabled*, *3F8/IRQ4*, *2F8/IRQ3*, *3E8/IRQ4*, *2E8/IRQ3* and

Auto.

UART Mode Select

The field allows you to specify the operation mode for serial port “COM B”. Settings are:

<i>IrDA:</i>	IrDA-compliant Serial Infrared Port
<i>ASKIR:</i>	Amplitude Shift Keyed Infrared Port
<i>Normal:</i>	RS-232C Serial Port

RxD, TxD Active

The item determines the active of RxD, TxD. Settings: “*Hi, Hi*”, “*Hi, Lo*”, “*Lo, Hi*”, “*Lo, Lo*”.

IR Transmission Delay

The field enables or disables IR transmission delay function. Settings: *Enabled* and *Disabled*.

UR2Duplex Mode

The field specifies a duplex value for the IR device connected to COM B. Full Duplex mode permits simultaneous two-direction transmission. Half Duplex mode permits transmission in one direction only at a time. Settings: *Half* and *Full*.

Use IR Pins

Consult your IR peripheral documentation to select the correct setting of TxD and RxD signals. Settings: *IR-Rx2Tx2* and *RxD2, TxD2*.

Onboard Parallel Port

This specifies the I/O port address and IRQ of the onboard parallel port. Settings: *378/IRQ7*, *278/IRQ5*, *3BC/IRQ7* and *Disabled*.

Parallel Port Mode

This item selects the operating mode for the parallel port: *SPP*, *EPP*, *ECP* or *ECP+EPP*.

EPP Mode Select

The item selects the EPP version used by the parallel port if it is set to

Chapter 3

EPP or *ECP+EPP* mode. Settings: *EPP1.7* and *EPP1.9*.

ECPModeUseDMA

The item specifies the DMA channel 1 or 3 for the parallel port when it is set to *ECP* or *ECP+EPP* mode.

Init Display First

This item specifies which VGA card is your primary graphics adapter. Available settings: *PCI Slot* and *AGP*.

OnChip USB Controller

The item specifies which USB (Universal Serial Bus) Port is enabled. Settings: *All Disabled*, *ALL Enabled*, *2&3 USB Port*, *1&2 USB Port*, *1&3 USB Port*, *3 USB Port*, *2 USB Port*, *1 USB Port*.

USB Keyboard Support

Set to *Enabled* if you need to use an USB keyboard in the operating system that does not support or have any USB driver installed, such as DOS and SCOUnix.

IDE HDD Block Mode

This allows your hard disk controller to use the fast block mode to transfer data to and from the hard disk drive. Block mode is also called block transfer, multiple commands or multiple sector read/write. *Enabled* enables IDE controller to use block mode; *Disabled* allows the controller to use standard mode.

PWRON After PWR-Fail

This item specifies whether your system will reboot after a power failure or interrupt occurs. Available settings are:

- | | |
|-------------------|----------------------------------------------------------------------------------------|
| <i>Off</i> | Leaves the computer in the power off state. |
| <i>On</i> | Reboots the computer. |
| <i>Former-Sts</i> | Restores the system to the previous status before power failure or interrupt occurred. |

Power Status Led

This item sets how the system uses Power LED on the case to indicate the

suspend/sleep state. Settings are:

Single The Power LED blinks to indicate the suspend/sleep state.

Dual The Power LED changes its color to indicate the suspend/sleep state.

Chapter 3

Power Management Setup

CMOS Setup Utility - Copyright (C) 1984-2001 Award Software
Power Management Setup

ACPI function	Enabled	Item Help
ACPI Suspend Type	S1(POS)	
Power Management Option	User Define	
HDD Power Down	Disable	Menu Level ▶
Suspend Mode	Disable	
Video Off Option	Suspend-> Off	
Video Off Mehtod	V/H SYNC+Blank	
MODEM Use IRQ	3	
Soft-Off by PWRBTN	Instant-Off	
▶ IRQ/Event Activity Detect	Press Enter	

↑↓→←:Move Enter:Select +/-/PU/PD:Value F10:Save ESC:Exit F1:General Help
F5: Previous Values F6: Fail-Safe Defaults F7: Optimized Defaults

ACPI function

This item is to activate the ACPI (Advanced Configuration and Power Management Interface) function. If your operating system is ACPI-aware, such as Windows 98SE/2000/ME, select *Enabled*. Settings: *Enabled* and *Disabled*.

ACPI Suspend Type

This item specifies the power saving modes for ACPI function. Options are:

- S1(POS)* The S1 sleep mode is a low power state. In this state, no system context (CPU or chipset) is lost and hardware maintains all system context.
- S3(STR)* The S3 sleep mode is a power-down state in which power is supplied only to essential components such as main memory and wake-capable devices and all system context is saved to main memory. The information stored in memory will be used to restore the PC to

the previous state when an “wake up” event occurs.

Power Management Option

This item is used to select the degree (or type) of power saving and is related to the mode: Suspend Mode. There are three options for power management:

- Min Saving* Minimum Power Management. Suspend Mode = 1 hour.
- Max Saving* Maximum Power Management. Suspend Mode = 1 Min.
- User Define* Allows end users to configure the suspend mode manually.

HDD Power Down

If HDD activity is not detected for the length of time specified in this field, the hard disk drive will be powered down while all other devices remain active. Settings: *Disable* and *1 Min* through *15 Min*.

Suspend Mode

If system activity is not detected for the length of time specified in this field, all devices except CPU will be shut off. Settings: *Disable*, *1 Min*, *2 Min*, *4 Min*, *6 Min*, *8 Min*, *10 Min*, *20 Min*, *30 Min*, *40 Min* and *1 Hour*.

Video Off Option

This option is for choosing the setting in which the monitor will be turned off.

- Always On* Always turn on.
- Suspend --> Off* During Suspend mode, the monitor will be turned off.

Video Off Method

This determines the manner in which the monitor is blanked.

- Blank Screen* This option only writes blanks to the video buffer.
- V/H SYNC+Blank* This selection will cause the system to turn off the vertical and horizontal synchroniza-

Chapter 3

DPMS Support

tion ports and write blanks to the video buffer.
Initial display power management signaling.

MODEMUseIRQ

Name the interrupt request (IRQ) line assigned to the modem (if any) on your system. Activity of the selected IRQ always awakens the system. Settings: 3, 4, 5, 7, 9, 10, 11 and NA.

Soft-Off by PWRBTN

This feature allows users to configure the power button function. Settings are:

- Instant-Off* The power button functions as a normal power-on/-off button.
- Delay 4 Sec* When you press the power button, the computer enters the suspend/sleep mode, but if the button is pressed for more than four seconds, the computer is turned off.

IRQ/Event Activity Detect

Press <Enter> to enter the sub-menu and the following screen appears:

IRQ/Event Activity Detect		
VGA	OFF	Item Help
LPT & COM	LPT/COM	
HDD & FDD	ON	Menu Level ▶ ▶
PCI Master	OFF	
USB Resume from S3	Disabled	
PowerOn by PCI Card	Disabled	
Wake Up On LAN/Ring	Disabled	
X RTC Alarm Resume	Disabled	
X Date (of Month)	0	
▶ Resume Time (hh:mm:ss)	0 : 0 : 0	
IRQs Activity Monitoring	Press Enter	

VGA, LPT & COM, HDD & FDD, PCI Master, USB Resume from S3, PowerOn by PCI Card, Wake Up On LAN/Ring

The fields specify whether the system will be awakened from power saving modes when activity or input signal of the specified hardware

peripheral or component is detected.



Note: To use the function of Wake Up On LAN/Ring, you need to install a modem/LAN card supporting power on function.

RTC Alarm Resume

The field is used to enable or disable the feature of booting up the system on a scheduled time/date.

Date (of Month)

Use the field to specify the date for RTC Alarm Resume. Settings: 0~31.

Resume Time (hh:mm:ss)

Use the field to specify the time for RTC Alarm Resume. Format is <hour><minute><second>.

IRQs Activity Monitoring

Press <Enter> to enter the sub-menu and the following screen appears:

IRQs Activity Monitoring

		Item Help
Primary INTR	ON	
IRQ3 (COM 2)	Enabled	
IRQ4 (COM 1)	Enabled	
IRQ5 (LPT 2)	Enabled	
IRQ6 (Floppy Disk)	Enabled	Menu Level ▶ ▶ ▶
IRQ7 (LPT 1)	Enabled	
IRQ8 (RTC Alarm)	Disabled	
IRQ9 (IRQ2 Redir)	Disabled	
IRQ10 (Reserved)	Disabled	
IRQ11 (Reserved)	Disabled	
IRQ12 (PS/2 Mouse)	Enabled	
IRQ13 (Coprocessor)	Enabled	
IRQ14 (Hard Disk)	Enabled	
IRQ15 (Reserved)	Disabled	

Primary INTR

Selecting *ON* will cause the system to wake up from power saving modes if activity is detected from any enabled IRQ channels.

IRQ3~IRQ15

Enables or disables the monitoring of the specified IRQ line. If set to *Enabled*, the

Chapter 3

activity of the specified IRQ line will prevent the system from entering power saving modes or awaken it from power saving modes.



Note: *IRQ (Interrupt Request) lines are system resources allocated to I/O devices. When an I/O device needs to gain attention of the operating system, it signals this by causing an IRQ to occur. After receiving the signal, when the operating system is ready, the system will interrupt itself and perform the service required by the I/O device.*

PnP/PCI Configurations

CMOS Setup Utility - Copyright (C) 1984-2001 Award Software
PnP/PCI Configurations

PNP OS Installed	No	Item Help
Reset Configuration Data	Disabled	
PCI/VGA Palette Snoop	Disabled	Menu Level ▶ Select Yes if you are using a Plug and Play capable operating system Select No if you need the BIOS to configure non-boot devices
Assign IRQ For VGA	Enabled	
Assign IRQ For USB	Enabled	
Slot1/5	INTA	
Slot2/IDE RAID	INTA	
Slot3/i82559	INTA	
Slot4	INTA	
↑↓→←:Move Enter:Select +/-/PU/PD:Value F10:Save ESC:Exit F1:General Help F5: Previous Values F6: Fail-Safe Defaults F7: Optimized Defaults		

PNP OS Installed

When set to *YES*, BIOS will only initialize the PnP cards used for booting (VGA, IDE, SCSI). The rest of the cards will be initialized by the PnP operating system like Windows® 95 or 98. When set to *NO*, BIOS will initialize all the PnP cards. So, select *Yes* if the operating system is Plug & Play aware.

Reset Configuration Data

The ESCD (Extended System Configuration Data) is a method that the BIOS uses to store resource information for both PNP and non PNP devices in a bit string format. When *Enabled*, the system will rebuild ESCD and you will see the message “ESCD Update Successfully” on boot up.

PCI/VGA Palette Snoop

PCI VGA palette is the set of colors currently used by the video device. Some special VGA cards may not show colors correctly and need to look into the video device’s VGA palette to determine what colors are in use.

Chapter 3

Then you have to turn on the palette “snoop”, permitting the palette registers of both VGA devices to be identical. The setting must be set to *Enabled* if any non-standard VGA adapter card, such as MPEG card, installed in the system requires VGA palette snooping.

Assign IRQ For VGA/USB

Selecting *Enabled* allows BIOS to automatically assign IRQ resources for the specified hardware components. Choose *Disabled* if you want to release the IRQ.

Slot1/5 INTA, Slot2/IDE RAID INTA, Slot3/i82559 INTA, Slot4 INTA

The items specify IRQs for each of the hardware components. *Auto* allows BIOS to determine the IRQ automatically.

PC Health Status

This section is to monitor the current hardware status including CPU temperature, CPU Fan speed, Vcore etc. This is available only if there is hardware monitoring mechanism onboard.

CMOS Setup Utility - Copyright (C) 1984-2001 Award Software
PC Health Status

Case Open Warning	Disabled	Item Help
CPU Warning Temperature	Disabled	
Top Tech III Temp.	32°C/89°F	Menu Level ▶
Current CPU1 Temp.	58°C/132°F	
Current CPU2 Temp.	58°C/132°F	
Current SYS FAN Speed	2310RPM	
Current CPU1 FAN Speed	4200RPM	
Current CPU2 FAN Speed	4560RPM	
CPU1 Vcore	1.66V	
CPU2 Vcore	1.65V	
Vio	3.26V	
+5V	5.02V	
+12V	12.05V	
-12V	-11.56V	
-5V	-4.99V	
VBAT(V)	3.22V	
5VSB(V)	4.87V	
Shutdown Temperature	Disabled	
SYS FAN Control	Run	
↑↓→←:Move Enter:Select +/-/PU/PD:Value F10:Save ESC:Exit F1:General Help F5: Previous Values F6: Fail-Safe Defaults F7: Optimized Defaults		

Case Open Warning

The item enables or disables the feature of recording the chassis intrusion status and issuing a warning message if the chassis was once opened. To clear the warning message, you must set the item to *Reset*. The setting of the item will automatically return to *Enabled* later. Settings: *Enabled*, *Enabled* and *Reset*.

CPU Warning Temperature

This item is used to specify a thermal limit for CPU. If CPU temperature reaches the specified limit, the system will issue a warning and allows you to prevent the CPU overheat problem. Settings: *Disabled*, *50°C/122°F*, *53°C/127°F*, *56°C/133°F*, *60°C/140°F*, *63°C/145°F*, *66°C/151°F* and *70°C/158°F*.

Chapter 3

Top Tech III Temp., Current CPU1/CPU2 Temp., Current SYS FAN Speed, Current CPU1/2 FAN Speed, CPU1/CPU2 Vcore, Vio, +5/+12V/-12V/-5V, VBAT(V), 5VSB(V)

These items display the current status of all of the monitored hardware devices/components such as CPU voltages, temperatures and all fans' speeds.

Shutdown Temperature

The item allows ACPI-aware OS to automatically shutdown if the system temperature reaches a thermal level preset in the field. This can prevent the system components from being damaged due to overheat. Settings: *Disabled, 60°C/140°F, 65°C/149°F, 70°C/158°F and 75°C/167°F.*

SYS FAN Control

The field allows you to determine whether the system fan connected to **SYSFN2** will work or not when the system is turned on. Settings: *Run and Stop.*

Frequency/Voltage Control

CMOS Setup Utility - Copyright (C) 1984-2001 Award Software
 Frequency/Voltage Control

Auto Detect PCI/DIMM Clk	Disabled	Item Help
Spread Spectrum	Enabled	
CPU Clock	100MHz	Menu Level ▶
CPU Ratio	X 4	
↑↓→←:Move Enter:Select +/-/PU/PD:Value F10:Save ESC:Exit F1:General Help F5: Previous Values F6: Fail-Safe Defaults F7: Optimized Defaults		

Auto Detect DIMM/PCI Clk

This item is used to auto detect the DIMM/PCI slots. When set to *Enabled*, the system will remove (turn off) clocks from empty DIMM/PCI slots to minimize the electromagnetic interference (EMI). Settings: *Enabled* and *Disabled*.

Spread Spectrum

When the motherboard clock generator pulses, the extreme values (spikes) of the pulses creates EMI (Electromagnetic Interference). The Spread Spectrum function reduces the EMI generated by modulating the pulses so that the spikes of the pulses are reduced to flatter curves. If you do not have any EMI problem, leave the setting at *Disabled* for optimal system stability and performance. But if you are plagued by EMI, setting to *Enabled* for EMI reduction. Remember to disable Spread Spectrum if you are overclocking because even a 0.25% jitter can introduce a temporary boost in clock speed of 25MHz (with a 1GHz CPU) which may just cause your overclocked processor to lock up.

Chapter 3

CPU Clock

This item specifies the CPU host bus (FSB). It provides end users an overclocking method.

CPU Ratio

This item is used to specify the CPU ratio (clock multiplier) and provides a tool for users to overclock the processor. Settings range from *X 3* to *X 16*.

Load Fail-Safe/Optimized Defaults

The two options on the main menu allow users to restore all of the BIOS settings to the default Fail-Safe or Optimized values. The Optimized Defaults are the default values set by the mainboard manufacturer specifically for the optimal performance of the mainboard. The Fail-Safe Defaults are the default values set by the BIOS vendor for the stable system performance.

When you select Load Fail-Safe Defaults, a message as below appears:

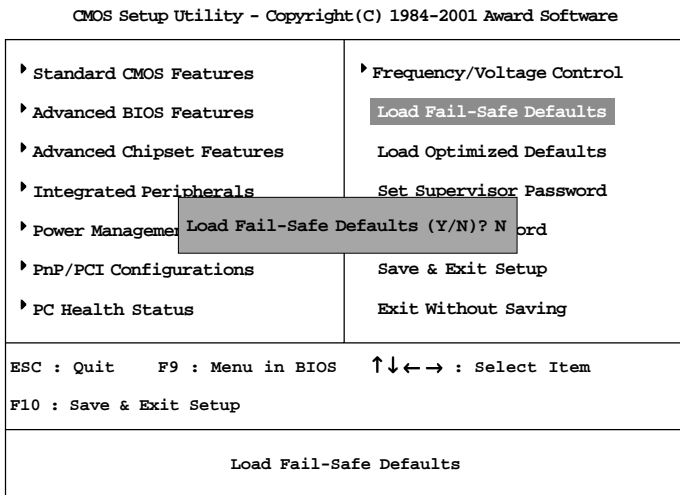

Pressing Y loads the BIOS default values for the most stable, minimal system performance.

Chapter 3

When you select Load Optimized Defaults, a message as below appears:

CMOS Setup Utility - Copyright(C) 1984-2001 Award Software

▸ Standard CMOS Features	▸ Frequency/Voltage Control
▸ Advanced BIOS Features	Load Fail-Safe Defaults
▸ Advanced Chipset Features	Load Optimized Defaults
▸ Integrated Peripherals	Set Supervisor Password
▸ Power Management	Load Optimized Defaults (Y/N)? N
▸ PnP/PCI Configurations	Save & Exit Setup
▸ PC Health Status	Exit Without Saving

ESC : Quit F9 : Menu in BIOS ↑↓←→ : Select Item
F10 : Save & Exit Setup

Load Optimized Defaults

Pressing Y loads the default factory settings for optimal system performance.

Set Supervisor/User Password

When you select this function, a message as below will appear on the screen:

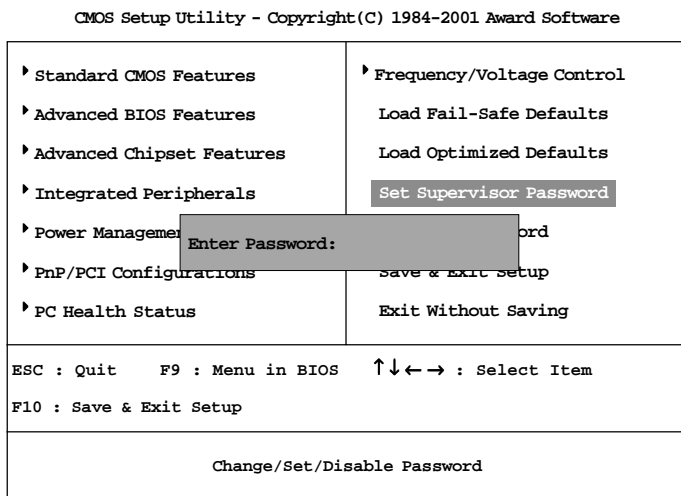

Type the password, up to eight characters in length, and press <Enter>. The password typed now will replace any previously set password from CMOS memory. You will be prompted to confirm the password. Re-type the password and press <Enter>. You may also press <Esc> to abort the selection and not enter a password.

To clear a set password, just press <Enter> when you are prompted to enter the password. A message will show up confirming the password will be disabled. Once the password is disabled, the system will boot and you can enter Setup without entering any password.

When a password has been set, you will be prompted to enter it every time you try to enter Setup. This prevents an unauthorized person from changing any part of your system configuration.

Additionally, when a password is enabled, you can also have BIOS to request a password each time the system is booted. This would prevent unauthorized

Chapter 3

use of your computer. The setting to determine when the password prompt is required is the Security Option of the Advanced BIOS Features menu. If the Security Option is set to *System*, the password is required both at boot and at entry to Setup. If set to *Setup*, password prompt only occurs when trying to enter Setup.



About Supervisor Password & User Password:

Supervisor password :

Can enter and change the settings of the setup menu.

User password:

Can only enter but do not have the right to change the settings of the setup menu.

Save & Exit Setup

When you want to quit the Setup menu, you can select this option to save the changes and quit. A message as below will appear on the screen:

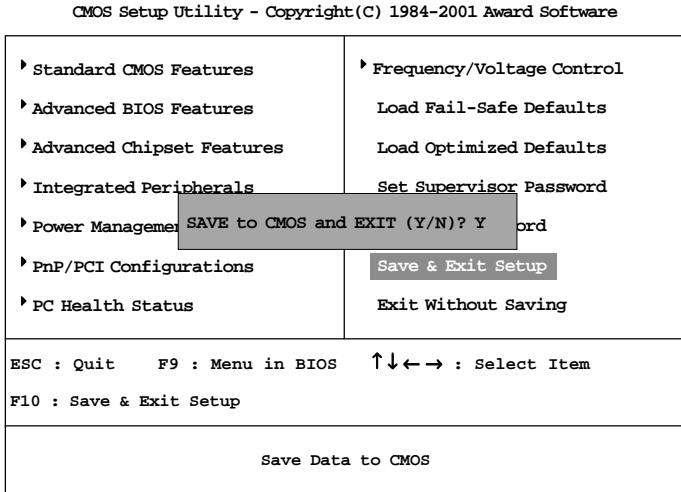

Typing *Y* will allow you to quit the Setup Utility and save the user setup changes to RTC CMOS.

Typing *N* will return to the Setup Utility.

Chapter 3

Exit Without Saving

When you want to quit the Setup menu, you can select this option to abandon the changes. A message as below will appear on the screen:

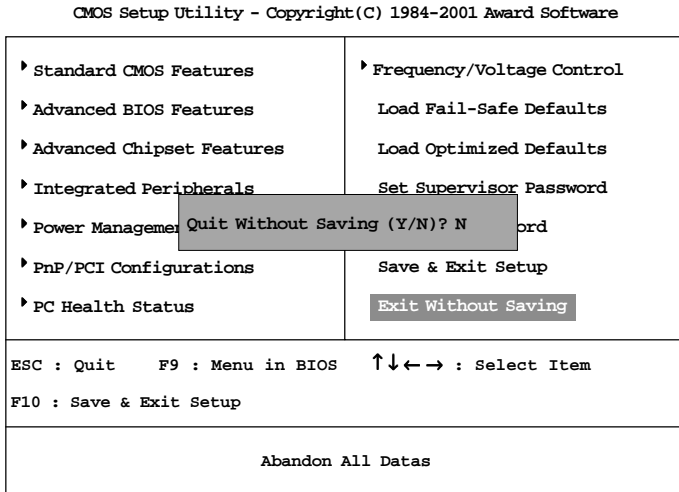

Typing *Y* will allow you to quit the Setup Utility without saving any changes to RTCCMOS.

Typing *N* will return to the Setup Utility.