



Apollo/Shadowhawk

U S E R M A N U A L





System Manual

Copyright

Premio is a registered trademark of Premio Computer, Inc. All other brands and product names are trademarks or registered trademarks of their respective companies.

© 1997 by Premio Computer, Inc. All rights reserved.

Printed in Taiwan.

Apollo/Shadowhawk, May 2000.

Disclaimers

Premio makes no representation or warranties, either expressed or implied, with respect to the contents of this publication and specifically disclaims the implied warranties of merchantability or fitness for a particular purpose. Premio shall not be liable for technical or editorial errors or omissions in this publication, or for incidental or consequential damages resulting from the furnishing, performance, or use of this publication. We reserve the right to revise this publication and to make changes from time to time in its contents without notification.

Contents

GETTING STARTED	1
Setting Up	2
Switches and Indicators	3
UPGRADING	5
Opening the System Unit	6
Installing an Expansion Card.....	7
Installing a Hard Drive	8
GETTING HELP	9
Troubleshooting	9
Monitor Does Not Work.....	9
Keyboard Does Not Work	10
Mouse Does Not Work.....	10
System Unit Problems	11
Hard Drive Problems.....	11
Technical Support	12
Premio on the Internet	12

APPENDIX.....	13
Warranty Policy	13
Service Under Warranty.....	14
Exclusions from Limited Warranty Programs.....	14
FCC Standards	15
Important Safety Instructions	16

Getting Started

Your Premio[®] system consists of three components:

- a mid-tower or desktop system unit
- a keyboard
- a mouse

Add your choice of monitor, and your system is ready to use.

Mid-tower system

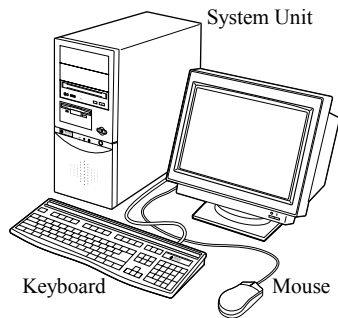

Desktop system

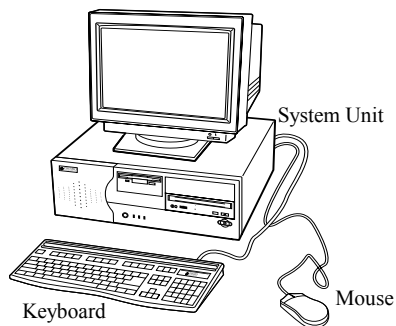

Setting Up

To set up your Premio system, simply connect your monitor, the mouse, the keyboard, and any additional components you want to use to the system unit.

Follow these easy steps:

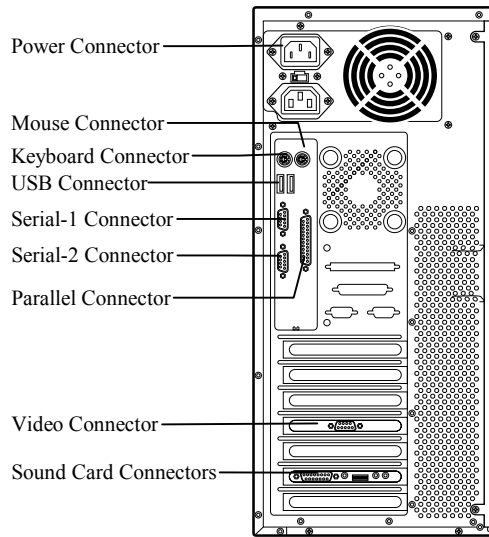

- 1** Attach your monitor's video cable to the video connector.
- 2** Attach the mouse cable to the mouse connector.
- 3** Attach the keyboard cable to the keyboard connector.
- 4** Attach the cables for any additional components, such as a printer, scanner, or modem, to the respective parallel, serial, or universal serial bus (USB) connector, as directed in the component's manual.
- 5** If your system is equipped for multimedia, attach your speakers and microphone to the sound card connectors.
- 6** Plug your monitor's power cord into a power outlet.
- 7** Attach the female end of the system power cord to the system unit's power connector, and then plug the other end of the cord into a power outlet.

Your Premio system is now ready to use. To start the system, turn on your monitor's power switch, and then press the system power switch as shown on the next page.

Switches and Indicators

The system unit's front panel provides access to the CD-ROM and floppy drives, and to the system's switches and indicator lights.

The illustration below shows a mid-tower system. If you have a desktop system, turn to the illustration on the next page.

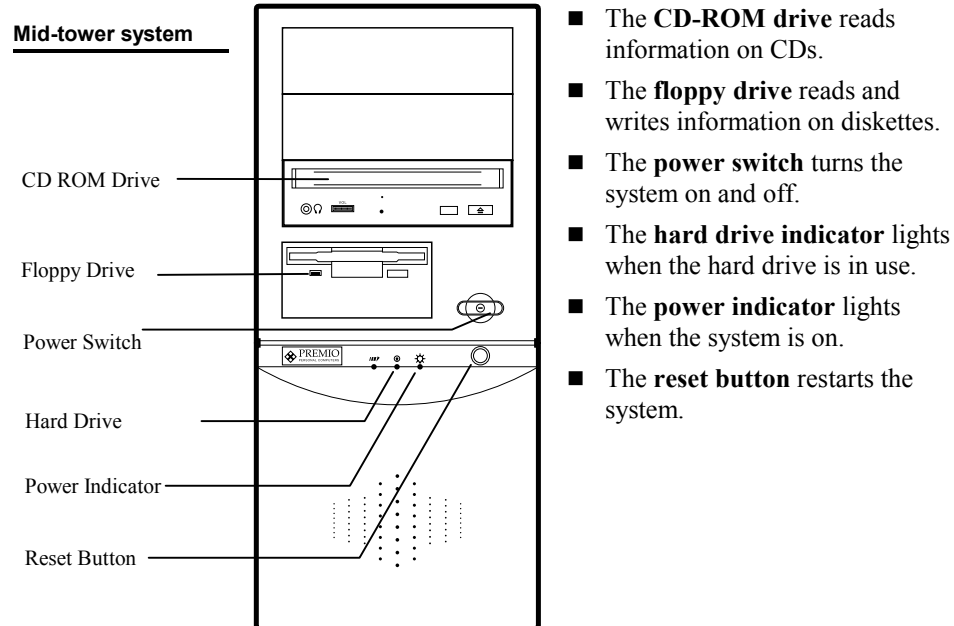

4 Premio System Manual

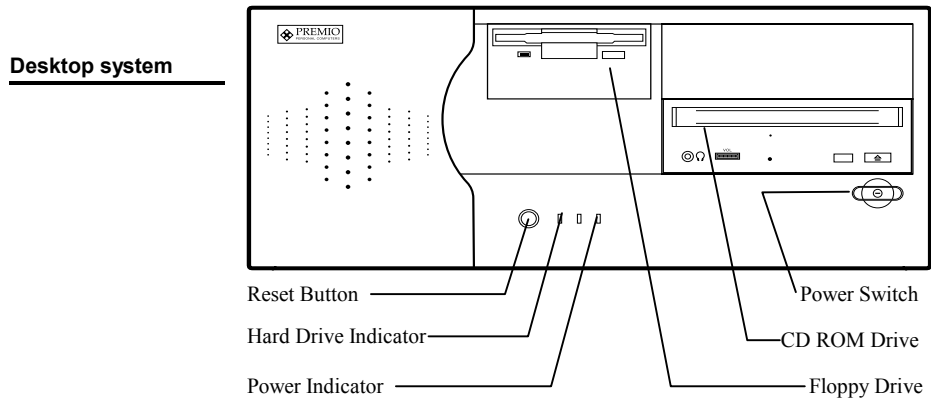

- The **reset button** restarts the system.
- The **hard drive indicator** lights when the hard drive is in use.
- The **power indicator** lights when the system is on.
- The **power switch** turns the system on and off.
- The **CD-ROM drive** reads information on CDs.
- The **floppy drive** reads and writes information on diskettes.

Upgrading

You can upgrade your Premio system with:

- Expansion cards
- More memory
- An additional hard drive

To install an upgrade, you must open the system unit. Before proceeding, read the important cautionary note below. Then follow the steps on the next page.

Caution! *Static discharge can cause permanent damage to internal electronic components of your computer. Always use the following precautions when working inside the system unit:*

- *Wear a grounding wrist strap (available at most electronics stores) when handling electronic components.*
- *Do not remove a component from its antistatic packaging until you are ready to install it.*
- *Keep one hand in contact with the metal system case.*

Opening the System Unit

Note: *Opening the system unit could affect your warranty. Check with the dealer where you purchased your system before opening the system unit.*

To open the system unit, follow these steps:

Mid-tower system

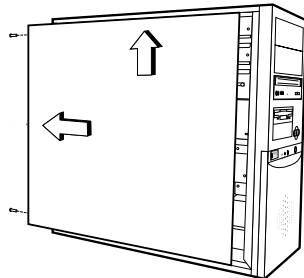

1 Turn off the system and unplug the power cord.

2 Remove the screws securing the side panel (mid-tower) or case (desktop) at the rear of the system unit.

Desktop system

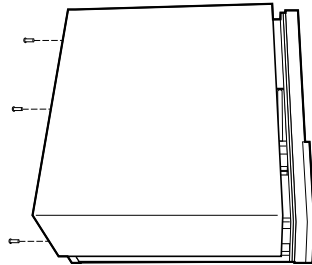

3 Slide the side panel or case up and to the rear, and remove it.

Installing an Expansion Card

To install an expansion card, open the system unit as described on the previous page. Then follow these steps:

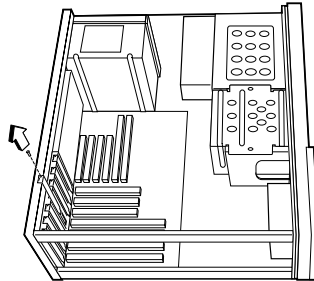

- 1** Remove the screw securing the slot bracket cover for the expansion slot you want to use. Save the screw to secure the expansion card.

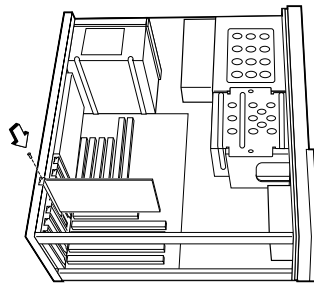

- 2** Insert the expansion card firmly into the slot, making sure it is seated completely.
- 3** Secure the card with the saved screw.

Installing a Hard Drive

To install a hard drive in your system, follow these steps:

- 1 Disconnect the hard drive cable and power connector.

Mid-tower system

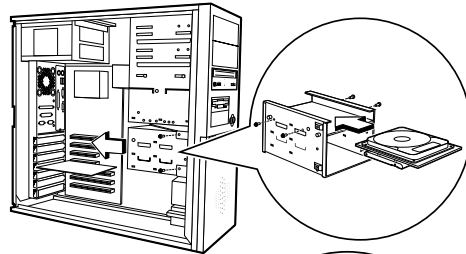

Desktop system

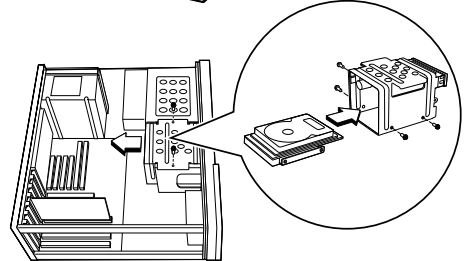

- 2 Remove the two screws securing the drive bay.
- 3 Slide the bay toward the rear of the system unit to remove it.
- 4 Insert the new drive into an open position in the bay and secure it with four screws.
- 5 Slide the bay back into the system unit and secure it with two screws.
- 6 Connect the cables.

Getting Help

Troubleshooting

Your Premio system is designed to provide years of trouble-free performance. If you have a problem with your system, you may wish to check the information in this section for a quick solution.

Monitor Does Not Work

If your monitor appears not to be working properly:

- Check that the monitor's power cable is securely attached to the monitor and to an outlet that is receiving power.
- Check that the monitor's video cable is securely attached to the monitor and to the system unit's video card connector.
- Check that the monitor's power switch is on.
- Adjust the monitor's brightness and contrast controls.
- If possible, substitute another monitor that is in good working order. If the substitute works, your monitor may need repair or replacement.

Keyboard Does Not Work

If the NumLock indicator in the upper right corner of the keyboard does not light when the system powers up, or the keyboard does not work:

- Check that the keyboard cable is securely attached to the system unit's keyboard connector.
- If possible, substitute another keyboard that is in good working order. If the substitute works, your keyboard may need replacement.

Mouse Does Not Work

If your mouse pointer does not move or moves erratically when you move the mouse:

- Check that the mouse cable is securely attached to the mouse connector on the system unit.
- Disassemble the mouse and clean the roller ball.

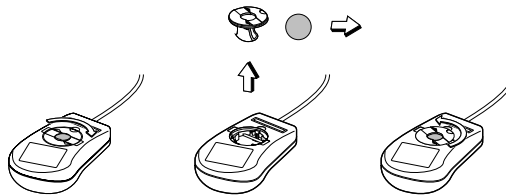

System Unit Problems

The fan inside the system unit should make a low, steady sound when operating properly.

If the fan is totally silent:

- Check that the system power cord is securely attached to the back of the system unit and to a power outlet. Verify that the outlet has power.
- If possible, substitute another power cord that is in good working order. If the substitute works, replace your power cord.

If the fan makes excessive noise:

- Turn off the system, open the system unit case, and inspect the fan for any obstructions.
- Turn on the system and listen closely to the fan. If the noise comes from inside the fan housing, your power supply may need replacement.

Hard Drive Problems

Your hard drive should make a slight whirring sound when operating properly.

If the drive is totally silent:

- Turn off the system, open the system unit case, and check that the power cable between the power supply and the hard drive is securely attached at both ends. If it is, your hard drive may be defective.

If the hard drive makes excessive noise:

- Turn off the system, open the system unit case, and remove the hard drive power cable connector from the hard drive. Then turn the system back on. If the noise disappears, your hard drive may be defective.
- If you have more than one hard drive, repeat the same procedure for each drive.

Technical Support

You can contact Premio technical support at the following address:

Premio Computer, Inc.

918 Radecki Court

City of Industry, CA 91748

Telephone: 626.839.3100

Fax: 626.839.3191

Email: support@premiopc.com

Web page: <http://support.premiopc.com>

Premio on the Internet

Premio maintains a web page on the Internet with the latest information on Premio products, updated drivers, answers to common problems, a troubleshooting guide, and more. Visit our web page at:

<http://www.premiopc.com>

Appendix

Warranty Policy

Premio Computer, Inc. warrants its line of Premio[®] computer systems to be free from defects in material and workmanship for a specific warranted period as stated below, from the date of original purchase from Premio Computer, Inc. or a Premio Computer, Inc. authorized reseller. This warranty is contingent upon proper use of the product in question and does not cover products which have been modified or which have been subjected to unusual physical or electrical stress. Warranty for third party hardware and software, if any, is subject to the third party's warranty policy. Please refer to the following for length of warranty for Premio's product line.

Premio Product	Warranty
Complete Premio System with monitor	3 years parts and labor
Premio Barebone (with or without CPU)	2 years parts and labor
Premio Monitor	2 year parts and labor
Premio OEM Component (motherboard, speaker, case, keyboard, mouse, floppy drive, CD-ROM, etc.)	2 years parts and labor

Service Under Warranty

If this product fails to be in good working order during the warranty period (or specific period of time as noted above), Premio Computer, Inc. will, at its option, repair or replace the product. Repair parts and/or replacement products may be either new or reconditioned at Premio Computer Inc.'s discretion. The limited warranty does not include service or repair for damage from improper installation, abuse or modifications to the product not approved in writing by Premio Computer, Inc. Any service repair outside the scope of this limited warranty will be at Premio Computer, Inc.'s or its Authorized Service Provider's rates and terms in effect. This warranty is valid only within the United States, Puerto Rico, Canada, Mexico and South America.

Exclusions from Limited Warranty Programs

All other expressed and implied warranties for this product are hereby disclaimed. If this product is not in good working order as warranted above, Premio Computer's sole and exclusive remedy shall be repair or replacement as stated above. In no event will Premio Computer, Inc. be liable to the customer or any third party for any damages in excess of the purchase price of the product. This limitation applies to damages of any kind including any direct or indirect damages, lost profits, lost savings or other special, incidental or consequential damages. This holds true for situations even if Premio Computer, Inc. or an authorized Premio representative or dealer has been advised of the possibility of such damages or of any claim by another party. Some states do not allow the exclusion or limitation of incidental or consequential damages for some products, so the above limitation or exclusion may not apply to you. Premio Computer, Inc. authorized resellers and service providers/partners may be changed, added or deleted, without notice or liability. Premio Computer, Inc. disclaims any authorized resellers and service provider/partner to the program. This warranty gives you specific legal rights and you may also have other rights, which may vary from state to state.

FCC Standards

This equipment has been tested and found to comply with the limits for a Class B digital device, pursuant to Part 15 of the FCC Rules. These limits are designed to provide reasonable protection against harmful interference in a residential installation. This equipment generates, uses and can radiate radio frequency energy and, if not installed and used in accordance with the instructions, may cause harmful interference to radio communications. However, there is no guarantee that interference will not occur in a particular installation. If this equipment does cause harmful interference to radio or television reception, which can be determined by turning the equipment off and on, the user is encouraged to try to correct the interference by one or more of the following measures:

- Reorient or relocate the receiving antenna.
- Increase the separation between the equipment and receiver.
- Connect the equipment into an outlet on a circuit different from that to which the receiver is connected.
- Consult the dealer or an experienced radio/TV technician for help.

Important Safety Instructions

These instructions are provided by Underwriters Laboratories, Inc.

1. Read all of these instructions and save them for later reference.
2. Follow all warnings and instructions marked on the product.
3. Unplug this product from the wall outlet before cleaning. Do not use liquid or aerosol cleaners. Use a damp cloth for cleaning.
4. Do not use this product near water.
5. Do not place this product on an unstable cart, stand or table. The product may fall, causing serious damage to the product.
6. Slots and openings on the cabinet and the back or bottom are provided for ventilation. To ensure reliable operation of the product and to protect it from overheating, do not block or cover these openings. The openings should never be blocked by placing the product on a bed, sofa, rug or other similar surface. This product should never be placed near or over a radiator or heat register. This product should not be placed in a built-in installation unless proper ventilation is provided.
7. This product should be operated from the type of power source indicated on the marking label. If you are not sure of the type of power available, consult your dealer or local power company.
8. This product is equipped with a 3-wire grounding-type plug, a plug having a third (grounding) pin. This plug will only fit into a grounding-type power outlet. This is a safety feature. If you are unable to insert the plug into the outlet, contact your electrician to replace your obsolete outlet. Do not defeat the safety purpose of the grounding-type plug.
9. Do not allow anything to rest on the power cord. Do not locate this product where the cord will be walked on.
10. If an extension cord is used with this product, make sure that the total of the ampere ratings on the products plugged into the extension cord do not exceed the extension cord ampere rating. Also, make sure that the total of all products plugged into the wall outlet does not exceed 15 amperes.
11. Never push objects of any kind into this product through cabinet slots as they may touch dangerous voltage points or short out parts

that could result in a risk of fire or electric shock. Never spill liquid of any kind on the product.

12. Except as explained elsewhere in this manual, don't attempt to service this product yourself. Opening and removing those covers that are marked "Do Not Remove" may expose you to dangerous voltage points or other risks. Refer all servicing on those compartments to service personnel.
13. Unplug this product from the wall outlet and refer servicing to qualified service personnel under the following conditions:
 - A. When the power cord or plug is damaged or frayed.
 - B. If liquid has been spilled into the product.
 - C. If the product has been exposed to rain or water.
 - D. If the product does not operate normally when the operating instructions are followed. Adjust only those controls that are covered by the operating instructions since improper adjustment of other controls may result in damage and will often require extensive work by a qualified technician to restore the product to normal operation.
 - E. If the product has been dropped or the cabinet has been damaged.
 - F. If the product exhibits a distinct change in performance, indicating a need for service.

Chapter 1

INTRODUCTION

The 815E PRO (MS-6337) ATX S3 mainboard is a high-performance computer mainboard based on Intel® 815 chipset. The MS-6337 is optimized to support the Intel® Pentium® III (FC-PGA) processor for high-end business/personal desktop markets.

The Intel® 815 chipset integrates a Display Cache SDRAM controller that supports a 32-bit 133MHz SDRAM array for enhanced integrated 3D graphics performance. It is a highly-flexible chipset which is designed to extend the basic graphics/multimedia PC platform up to the mainstream performance desktop platform.

The Intel® 815 chipset implements the host address, control, and data bus interfaces within a single device. It takes advantage of the pipelined addressing capability of the processor to improve the overall system performance. In addition, the chipset also integrates a system memory controller that supports a 64-bit 100/133 MHz SDRAM array.

The Intel® 82801BA (ICH2) chipset is a highly integrated multifunctional I/O Controller Hub that provides the interface to the PCI Bus and integrates many of the functions needed in today's PC platforms. It communicates with the host controller over a dedicated hub interface and provides added flexibility in designing cost-effective system solutions.

1.1 Mainboard Features

CPU

- Support Socket370 for Intel® Celeron™/Pentium® III(FC-PGA) processor.
- Support 500MHz, 550MHz, 600MHz, 633MHz, 667MHz and up to 1GHz

Chipset

- Intel® Solano chipset. (544 BGA)
 - AGP 4x/2x universal slot
 - Support 66/100/133MHz FSB
- Intel® ICH2 chipset. (241 BGA)
 - AC'97 6-channel support
 - Integrated LAN controller
 - 2 full IDE channels, up to ATA100
 - Low pin count interface for SIO
 - 2 USB host controller/4USB ports

Main Memory

- Support four 168-pin DIMM sockets.
- Support a maximum memory size of 256MB or 512MB SDRAM.

Slots

- One CNR (Communication Network Riser).
- One AGP (Accelerated Graphics Port) 2x/4x slot.
- Six PCI 2.2 32-bit Master PCI Bus slots. All PCI slots can be used as master. (One PCI/ISA slot shared; ISA slot is optional).
- Support 3.3v/5v PCI bus Interface.

On-Board IDE

- An IDE controller on the ICH2 chipset provides IDE HDD/CD-ROM with PIO, Bus Master and Ultra DMA 66/100 operation modes.
- Can connect up to four IDE devices.

On-Board Peripherals

- On-Board Peripherals include:
 - 1 floppy port supports 2 FDD with 360K, 720K, 1.2M, 1.44M and 2.88Mbytes.
 - 1 serial port (COMA)
 - 1 parallel port supports SPP/EPP/ECP mode
 - 4 USB ports (Rear * 2 / Front * 2)
 - 1 VGA port

Video

- GMCH chip integrated
- 2D/3D Graphics
- Intel® D.V.M Technology
- Flexible AGP In-Line Memory Module (AIMM) (optional)
- One AGP slot for external AGP card

Audio

- ICH2 chip integrated
- Support 4 Channel Audio or 6 Channel Audio (optional)

BIOS

- The mainboard BIOS provides “Plug & Play” BIOS which detects the peripheral devices and expansion cards of the board automatically.
- The mainboard provides a Desktop Management Interface(DMI) function which records your mainboard specifications.

Dimension

- ATX Form Factor

Mounting

- 6 mounting holes.

1.2 Mainboard Layout

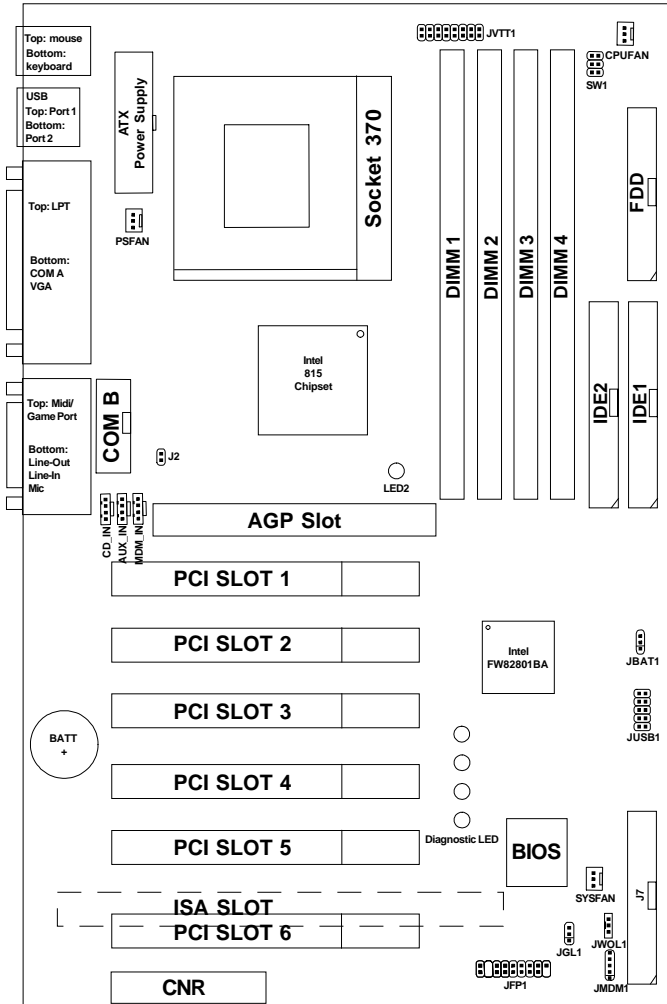

815E PRO (MS-6337) ATX S3 Mainboard

Chapter 2

HARDWARE INSTALLATION

2.1 Central Processing Unit: CPU

The mainboard operates with **Intel® Celeron™/Pentium® III (FC-PGA) processor**. The mainboard uses a CPU socket called Socket 370 for easy CPU installation. The CPU should always have a Heat Sink and a cooling fan attached to prevent overheating.

2.1-1 CPU Installation Procedures

1. Pull the lever sideways away from the socket. Then, raise the lever up to a 90-degree angle.
2. Locate Pin 1 in the socket and look for the white dot or cut edge in the CPU. Match Pin 1 with the white dot/cut edge. Then, insert the CPU. It should insert easily.
3. Press the lever down to complete the installation.

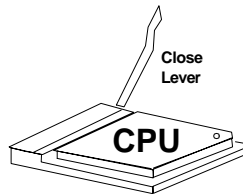
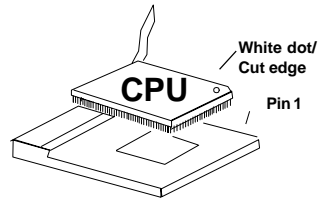
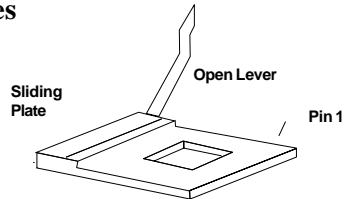

2.1-2 CPU Core Speed Derivation Procedure

The mainboard CPU Bus Frequency can be set through BIOS setup.

$$\begin{array}{ll} \textbf{If} & \text{CPU Clock} = 100\text{MHz} \\ & \text{Core/Bus ratio} = 7 \\ \textbf{then} & \text{CPU core speed} = \text{Host Clock} \times \text{Core/Bus ratio} \\ & = 700\text{MHz} \end{array}$$

2.1-3 Overclocking Jumper: SW1

Overclocking is operating a CPU/Processor beyond its specified frequency. SW1 jumper is used for overclocking.

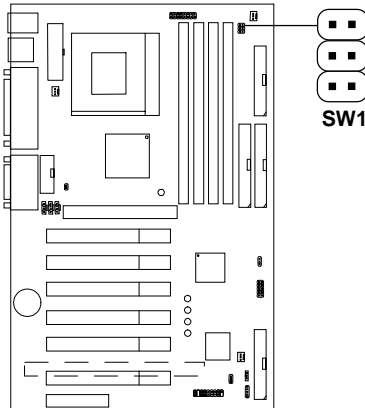

SW1	CPU Frequency
	Auto
	66.6 → 100
	133 → 66.6 100 → 66.6
	133 → 100

Note: If you used this jumper for overclocking, you also need to modify the CPU Bus ratio through BIOS.

2.1-4 Fan Power Connectors: CPUFAN, SYSFAN & PSFAN

These connector support system cooling fan with + 12V. It supports three pin head connector. When connecting the wire to the connector, always take note that the red wire is the positive and should be connected to the +12V, the black wire is Ground and should be connected to GND. If your mainboard has System Hardware Monitor chipset on-board, you must use a specially designed fan with speed sensor to take advantage of this function.

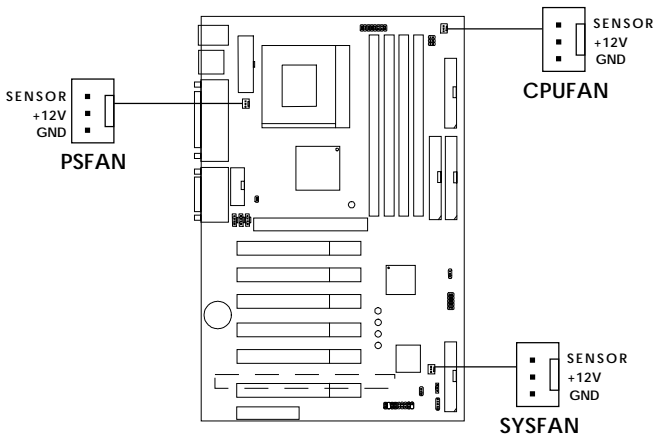

CPUFAN: Processor Fan

SYSFAN: System Fan

PSFAN: Power Supply Fan

For fans with fan speed sensor, every rotation of the fan will send out 2 pulses. System Hardware Monitor will count and report the fan rotation speed.

- Note:**
1. Always consult vendor for proper CPU cooling fan.
 2. CPU FAN supports the FAN control. You can install PC Alert utility. This will automatically control the CPU FAN Speed according to the actual CPU temperature.

2.2 Clear CMOS Jumper: JBAT1

A battery must be used to retain the mainboard configuration in CMOS RAM. Short 1-2 pins of JBAT1 to store the CMOS data.

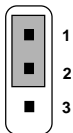
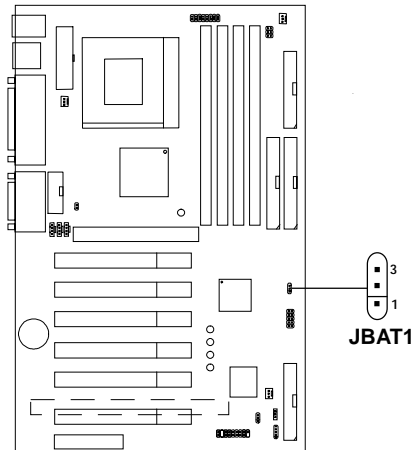

Keep Data

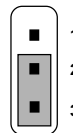

Clear Data

Note: You can clear CMOS by shorting 2-3 pin, while the system is off. Then, return to 1-2 pin position. Avoid clearing the CMOS while the system is on, it will damage the mainboard. Always unplug the power cord from the wall socket.

2.3 Memory Installation

2.3-1 Memory Bank Configuration

The mainboard supports a maximum memory size of 512MB: It provides four 168-pin **unbuffered** DIMMs (Double In-Line Memory Module) sockets. It supports 32MB to 512MB DIMM memory module.

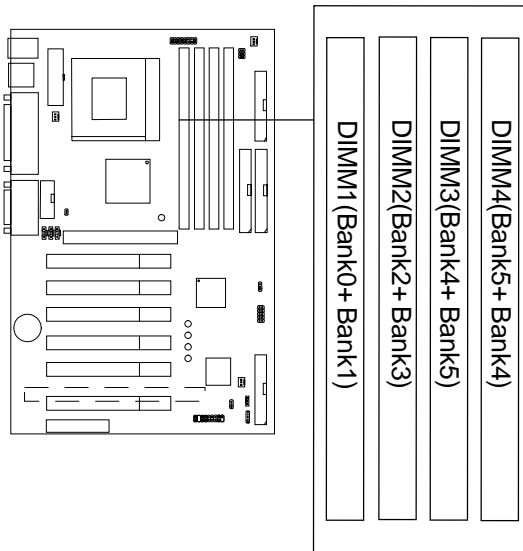

2.3-2 Memory Installation Procedures

A. How to install a DIMM Module

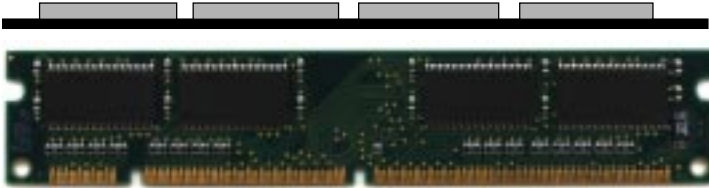

Single Sided DIMM

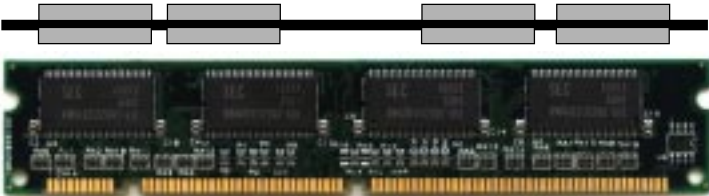

Double Sided DIMM

1. The DIMM slot has 2 Notch Keys “VOLT and DRAM”, so the DIMM memory module can only fit in one direction.
2. Insert the DIMM memory module vertically into the DIMM slot. Then push it in.

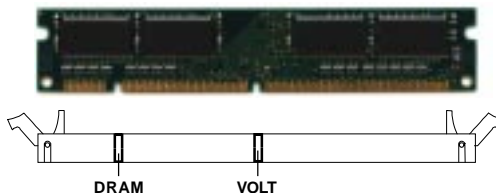

3. The plastic clip at the side of the DIMM slot will automatically close.

2.3-3 Memory Population Rules

1. Supports only SDRAM DIMM.
2. To operate properly, at least one 168-pin DIMM module must be installed.
3. This mainboard supports Table Free memory, so memory can be installed on DIMM1, DIMM2, DIMM3 or DIMM4 in any order.
4. Supports 3.3 volt DIMM.
5. The DRAM addressing and the size supported by the mainboard is shown at the next page.
6. Supports up to 3 Double Sided DIMMs at 100Mhz system memory bus and 2 Double Sided DIMMS at 133Mhz system memory bus.

Note: It is not recommended to install a Double Side DIMM module to DIMM 3 and DIMM 4 at the same time as this will not function properly. To make use of DIMM 3 and DIMM 4 at the same time, insert a Single Side DIMM module to each of them. Please use the same type or model of SDRAM. Moreover, you should always use DIMM 3 if you have only one Single Side DIMM module. Installing it on DIMM 4 is not allowed and this will not function properly. Refer to the table below for proper combination.

DIMM1	DIMM2	DIMM3	DIMM4
DS/SS	DS/SS	DS	X
DS/SS	DS/SS	SS	SS
DS/SS	DS/SS	X	DS
DS/SS	DS/SS	SS	X

DS: Double Side DIMM

SS: Single Side DIMM

X: None/Cannot be installed

Table 2.3-1 SDRAM Memory Addressing

DIMM Capacity	# of Devices/ DIMM	# of Sides	Dram Tech.	Front Side Population			Back Side Population			Row	Bank	Column
				Count	Config		Count	Config				
0		N/A		Empty			Empty			N/A	N/A	N/A
32MB	16	DS	16Mb	8-	2Mb	x8	8-	2Mb	x8	11	1	9
32MB	4	SS	64Mb	4-	4Mb	x16				12	2	8
48MB	12	DS	64/16Mb	4-	4Mb	x16	8-	2Mb	x8	12	2/1	8
64MB	8	DS	64Mb	4-	4Mb	x16	4-	4Mb	x16	12	2	8
64MB	8	SS	64Mb	8-	8Mb	x8				12	2	9
64MB	4	SS	128Mb	4-	8Mb	x16				12	2	9
96MB	12	DS	64Mb	8-	8Mb	x8	4-	4Mb	x16	12	2	9/8
96MB	8	DS	128/64Mb	4-	8Mb	x16	4-	4Mb	x16	12	2	9/8
128MB	16	DS	64Mb	8-	8Mb	x8	8-	8Mb	x8	12	2	9
128MB	8	DS	128Mb	4-	8Mb	x16	4-	8Mb	x16	12	2	9
128MB	8	SS	128Mb	8-	16Mb	x8				12	2	10
128MB	4	SS	256Mb	4-	16Mb	x16				13	2	9
192MB	12	DS	128Mb	8-	16Mb	x8	4-	8Mb	x16	12	2	10/9
192MB	16	DS	128/64Mb	8-	16Mb	x8	8-	8Mb	x8	12	2	10/9
256MB	16	DS	128Mb	8-	16Mb	x8	8-	16Mb	x8	12	2	10
256MB	8	DS	256Mb	4-	16Mb	x16	4-	16Mb	x16	13	2	9
256MB	8	SS	256Mb	8-	32Mb	x8				13	2	10
512MB	16	DS	256Mb	8-	32Mb	x8	8-	32Mb	x8	13	2	10

2.4 Case Connector: JFP1

The Keylock, Power Switch, Reset Switch, Power LED, Speaker, and HDD LED are all connected to the JFP1 connector block.

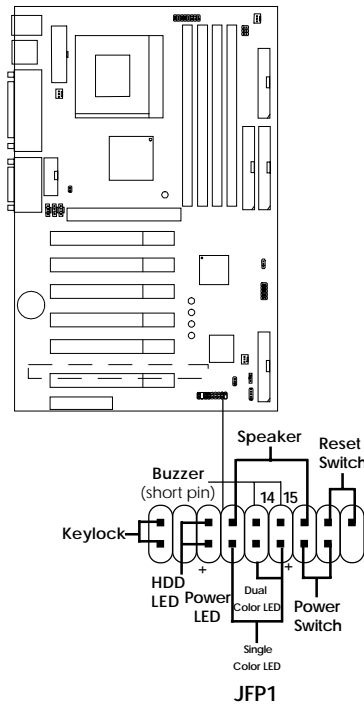

2.4-1 Power Switch

Connect to a 2-pin push button switch. This switch has the same feature with JRMS1.

2.4-2 Reset Switch

Reset switch is used to reboot the system rather than turning the power ON/OFF. Avoid rebooting while the HDD LED is lit. You can connect the Reset switch from the system case to this pin.

2.4-3 Power LED

The Power LED is lit while the system power is on. Connect the Power LED from the system case to this pin. There are two types of LED that you can use: 3-pin single color LED or 2-pin dual color LED(ACPI request).

- a. 3 pin single color LED connect to pin 4, 5, & 6. This LED will lit when the system is on.
- b. 2 pin dual color LED connect to pin 5 & 6.
GREENColor: Indicate the system is in full on mode.
ORANGEColor: Indicate the system is in suspend mode.

2.4-4 Speaker

Speaker from the system case is connected to this pin.

If on-board Buzzer is available:

Short pin 14-15: On-board Buzzer Enabled.

Open pin 14-15: On-board Buzzer Disabled.

2.4-5 HDD LED

HDD LED shows the activity of a hard disk drive. Avoid turning the power off while the HDD led is lit. You can connect the HDD LED from the system case to this pin.

2.4-6 Keylock

Keylock allows you to disable the keyboard for security purposes. You can connect the keylock to this pin.

2.5 Floppy Disk Connector: FDD

The mainboard also provides a standard floppy disk connector FDD that supports 360K, 720K, 1.2M, 1.44M and 2.88M floppy disk types. This connector supports the provided floppy drive ribbon cables.

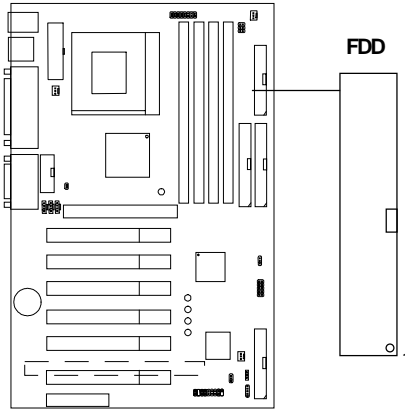

2.6 Hard Disk Connectors: IDE1 & IDE2

The mainboard has a 32-bit Enhanced PCI IDE and Ultra DMA 33/66/100 Controller that provides PIO mode 0~4, Bus Master, and Ultra DMA/33/66/100 function. It has two HDD connectors IDE1 (primary) and IDE2 (secondary). You can connect up to four hard disk drives, CD-ROM, 120MB Floppy (reserved for future BIOS) and other devices to IDE1 and IDE2. These connectors support the provided IDE hard disk cable.

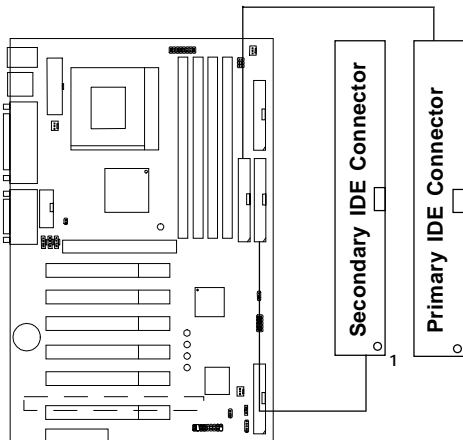

IDE1(Primary IDE Connector)

The first hard drive should always be connected to IDE1. IDE1 can connect a Master and a Slave drive. You must configure second hard drive to Slave mode by setting the jumper accordingly.

IDE2(Secondary IDE Connector)

IDE2 can also connect a Master and a Slave drive.

2.7 Power Supply

2.7-1 ATX 20-pin Power Connector: JWR

This connector supports the power button on-board. Using the ATX power supply, functions such as Modem Ring Wake-Up and Soft Power Off are supported by this mainboard. This power connector supports instant power on function which means that system will boot up instantly when the power connector is inserted on the board.

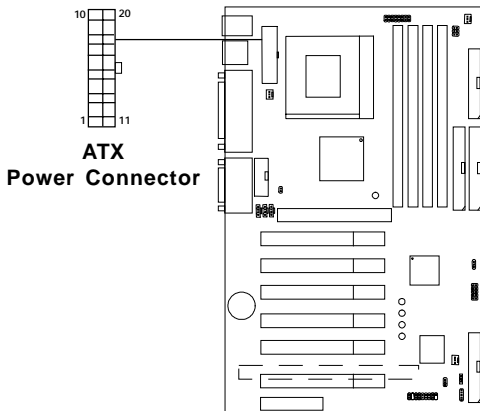

PIN DEFINITION

PIN	SIGNAL	PIN	SIGNAL
1	3.3V	11	3.3V
2	3.3V	12	-12V
3	GND	13	GND
4	5V	14	PS_ON
5	GND	15	GND
6	5V	16	GND
7	GND	17	GND
8	PW_OK	18	-5V
9	5V_SB	19	5V
10	12V	20	5V

Warning: Since the mainboard has the instant power on function, make sure that all components are installed properly before inserting the power connector to ensure that no damage will be done.

2.9 Serial Port Connectors: COM A and COM B

The mainboard has a 9-pin male DIN connector for serial port COM A. This port is a 16550A high speed communication port that send/receive 16 bytes FIFOs. You can attach a mouse or a modem cable directly into this connector.

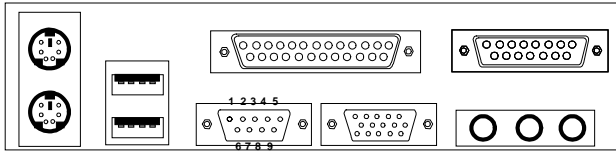

COM 1
Serial Port (9-pin Male)

PIN DEFINITION

PIN	SIGNAL
1	DCD (Data Carry Detect)
2	SIN (Serial In or Receive Data)
3	SOUT (Serial Out or Transmit Data)
4	DTR (Data Terminal Ready)
5	GND
6	DSR (Data Set Ready)
7	RTS (Request To Send)
8	CTS (Clear To Send)
9	RI (Ring Indicate)

Note:

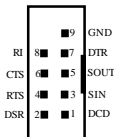

COM B

There's another serial port connector (COM B), which is located on the mainboard. Connect a serial port 9 pin male port into this connector.

2.10 Parallel Port Connector: LPT1

The mainboard provides a 25 pin female centronic connector for LPT. A parallel port is a standard printer port that also supports Enhanced Parallel Port(EPP) and Extended capabilities Parallel Port(ECP). See connector and pin definition below:

Parallel Port (25-pin Female)

LPT 1

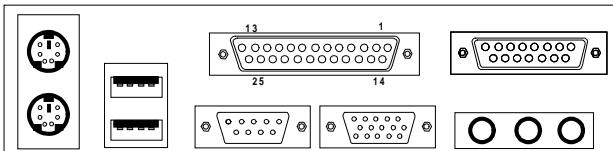

PIN DEFINITION

PIN	SIGNAL	PIN	SIGNAL
1	STROBE	14	AUTO FEED#
2	DATA0	15	ERR#
3	DATA1	16	INIT#
4	DATA2	17	SLIN#
5	DATA3	18	GND
6	DATA4	19	GND
7	DATA5	20	GND
8	DATA6	21	GND
9	DATA7	22	GND
10	ACK#	23	GND
11	BUSY	24	GND
12	PE	25	GND
13	SELECT		

2.11 Mouse Connector: JKBS1

The mainboard provides a standard PS/2[®] mouse mini DIN connector for attaching a PS/2[®] mouse. You can plug a PS/2[®] mouse directly into this connector. The connector location and pin definition are shown below:

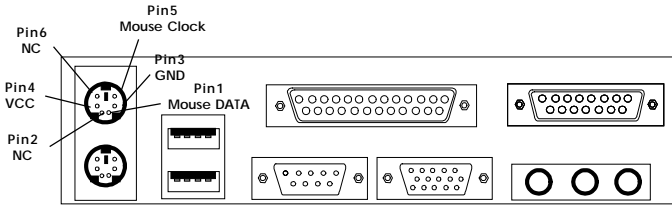

PS/2 Mouse (6-pin Female)

2.12 Keyboard Connector: JKBS1

The mainboard provides a standard PS/2[®] keyboard mini DIN connector for attaching a keyboard. You can plug a keyboard cable directly to this connector.

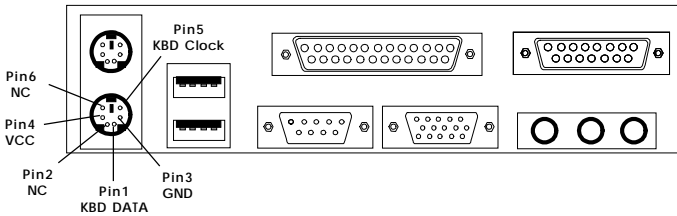

PS/2 Keyboard (6-pin Female)

2.13 Joystick/Midi Connectors

You can connect joystick or game pad to this connector.

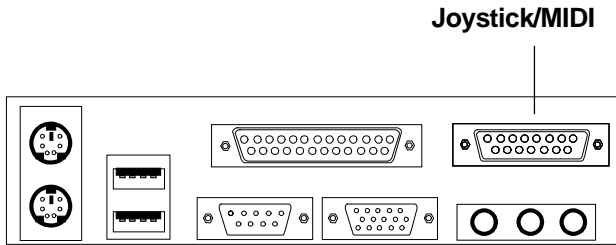

2.14 Audio Port Connectors

Line Out is a connector for Speakers or Headphones. **Line In** is used for external CD player, Tape player, or other audio devices. **Mic** is a connector for the microphones.

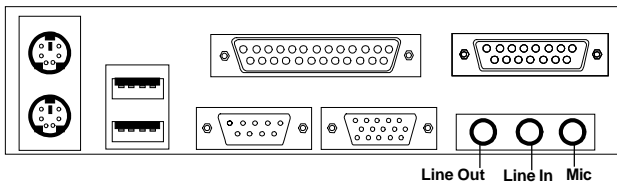

1/8" Stereo Audio Connectors

Note: If you choose to enable the Audio Multi-Channel, this will change the **Line In** to 3, 4 channel output and **MIC** to 5, 6 channel output (optional). To use this function, set the Audio Multi-Channel to enable located at the BIOS Integrated Peripherals or install the driver provided with this mainboard.

2.15 USB Connectors

The mainboard provides a **UHCI(Universal Host Controller Interface) Universal Serial Bus root** for attaching USB devices like: keyboard, mouse and other USB devices. You can plug the USB device directly to this connector.

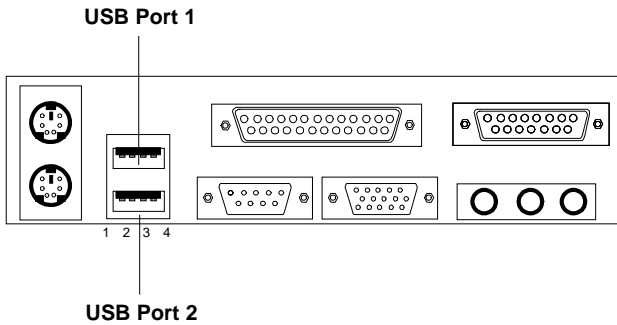

PIN	SIGNAL
1	VCC
2	-Data
3	+Data
4	GND

2.16 VGA DB 15 Pin Connector

The mainboard provides a DB 15-pin connector to connect to a VGA monitor.

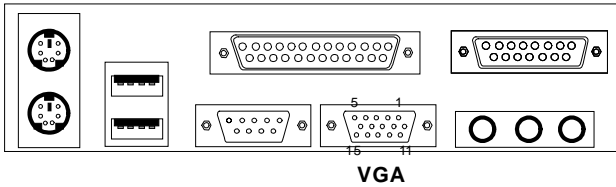

Analog Video Display Connector(DB15-S)	
Pin	Signal Description
1	Red
2	Green
3	Blue
4	Not used
5	Ground
6	Ground
7	Ground
8	Ground
9	Not used
10	Ground
11	Not used
12	SDA
13	Horizontal Sync
14	Vertical Sync
15	SCL

2.17 Power Saving LED Connector: JGL1(Reserved)

JGL1 can be connected with an LED. There are two types of LED that you can use: 3-pin LED or 2-pin LED(ACPI request). When the 2-pin LED is connected to JGL1, the light will turn green, when system is On. During sleep mode, the 2-pin LED will change color from Green to Orange. For 3-pin LED, when LED is connected to JGL1, this will light when the system is On and blinks when it is in suspend/sleep mode. See page 3-20 (Power status LED) for further instruction.

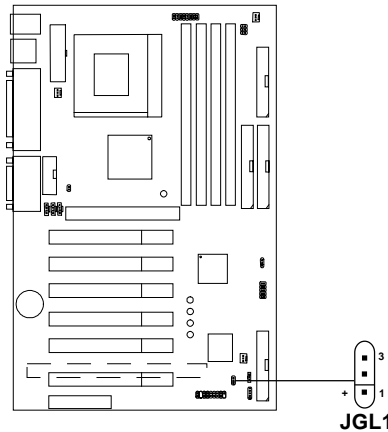

3-pin LED	2-pin LED
<p>1-2 Single Color 1-3 Blink</p>	<p>1-2 Dual Color</p>

2.18 Wake-Up on LAN Connector: JWOL1

The JWOL1 connector is for use with LAN add-on cards that supports Wake Up on LAN function. To use this function, you need to set the “Wake-Up on LAN” to enable at the BIOS Power Management Setup.

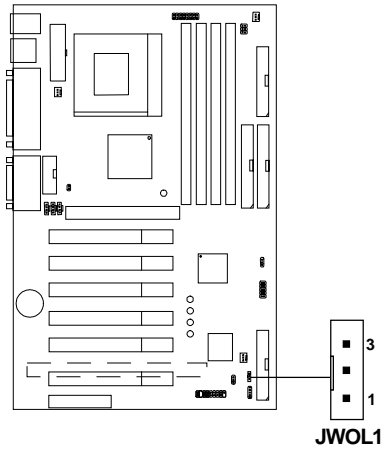

PIN	SIGNAL
1	5VSB
2	GND
3	MP_WAKEUP

Note: LAN wake-up signal is active “high”.

Note: To be able to use this function, you need a power supply that provide enough power for this feature. (Power supply with 750mA 5V Stand-by)

2.19 Modem Wake Up Connector: JMDM1

The JMDM1 connector is for use with Modem add-on card that supports the Modem Wake Up function.

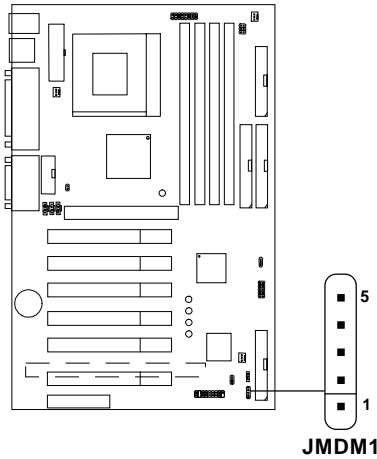

PIN	SIGNAL
1	NC
2	GND
3	MDM_WAKEUP
4	NC
5	5VSB

Note: Modem wake-up signal is active “low”.

Note: To be able to use this function, you need a power supply that provide enough power for this feature. (Power supply with 750mA 5V Stand-by)

2.20 Modem-In: MDM_IN

The connector is for Modem with internal voice connector.

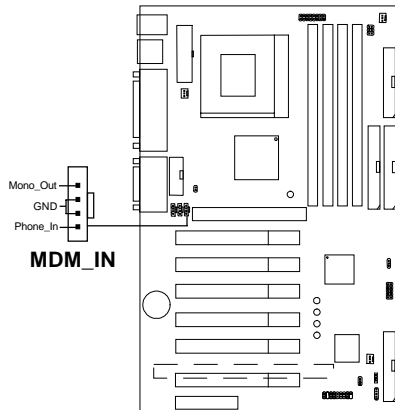

Mono_Out is connected to the Modem Speaker Out connector.

Phone_In is connected to the Modem Microphone In connector.

2.21 AUX Line In Connector: AUX_IN

This connector is used for DVD Add on Card with Line In connector.

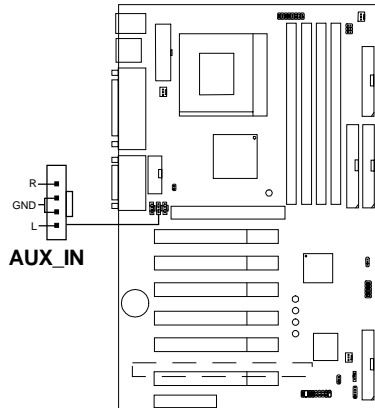

2.22 CD-In Connector: CD_IN

This connector is for CD-ROM audio connector.

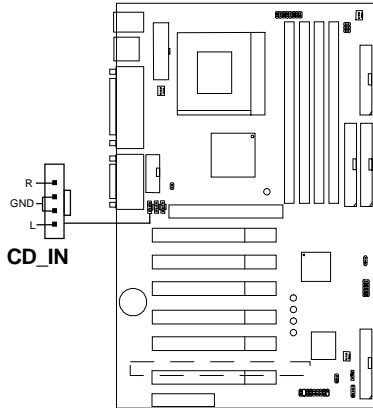

2.23 TOP TECH. III: J2

This is used to check the AGP card or any chipset temperature. The J2 is a 2-pin connector which can be inserted with a 20cm length thermistor. It is located near the chipset heatsink that monitors the chipset temperature. The BIOS setup for “TOP TECH III” should be set to enabled.

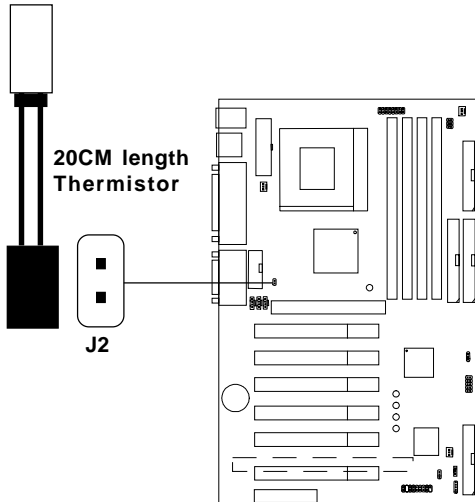

2.24 LED 2

The mainboard provides a Special Diagnostic LED for users to be aware of their mainboard conditions. LED 2 indicates the DIMM power. When LED 2 is powered on. Do not attempt to insert or remove the DIMM module.

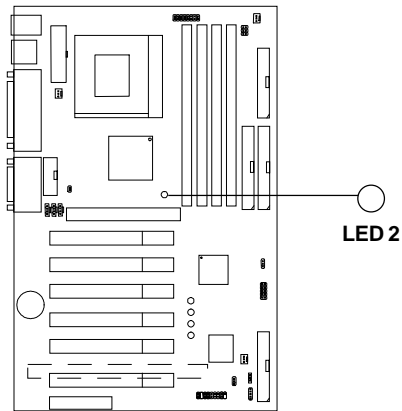

2.25 CNR (Communication Network Riser)

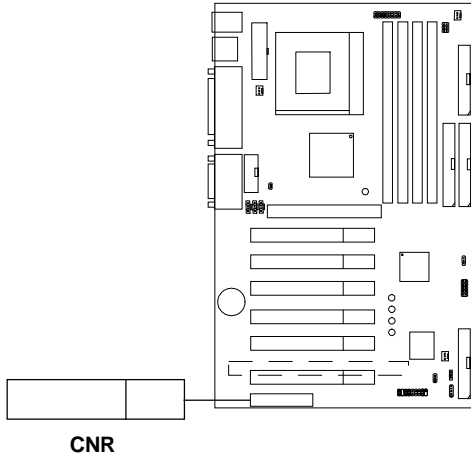

The Communication Network Riser specification is an open industry-standard specification that defines a hardware scalable Original Equipment Manufacturer (OEM) mainboard riser board and interface, which supports multi-channel audio, V.90 analog modem, phone-line based networking and 10/100 Ethernet based networking.

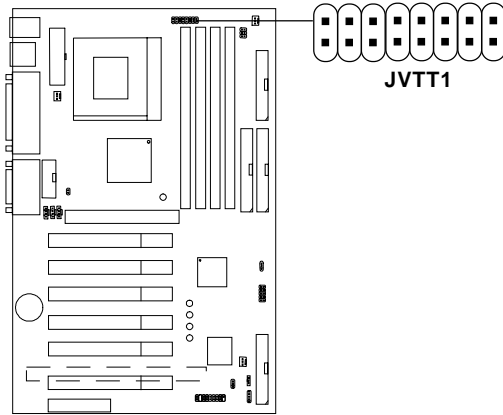

2.26 CPU Termination Voltage Jumper: JVTT1 (reserved)

The JVTT1 is a reserved function for future Coppermine CPU.



JVTT1	Function
	For Celeron
	For Coppermine

2.27 USB Front Connector: JUSB1

The mainboard provides a **front Universal Serial Bus connector**. This is an optional USB connector for Front Panel.

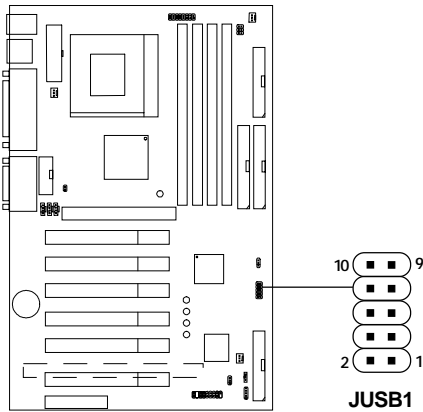

Pin	Description	Pin	Description
1	VCC	2	GND
3	USB2-	4	GND
5	USB2+	6	USB3+
7	GND	8	USB3-
9	GND	10	VCC

2.28 Diagnostic LED

The mainboard provides a Special Diagnostic LED for users to be aware of their mainboard conditions. The LED helps user determine the problem of the mainboard.

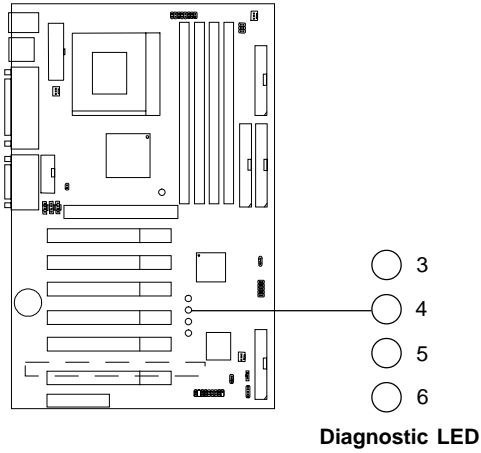

Diagnostic LED Function

Diagnostic LED 6 5 4 3	Description	Possible Problem/ Solution
0 0 0 0	System Power ON. This will start BIOS Initialization	System D-LED will hang here The Processor might be damage or not installed properly Damage/Discharge Lithium Battery
0 0 0 1	Early Chipset Initialization	***
0 0 1 0	Memory Detection Test Testing Onboard memory size	System D-LED will hang here The Memory module might be damage or not installed properly.
0 0 1 1	Decompressing BIOS image to RAM for fast booting.	***
0 1 0 0	Initializing Keyboard Controller	***
0 1 0 1	Testing VGA BIOS This will start writing VGA sign-on messages to the screen.	System D-LED will produce Beep sound The VGA card might be damage or not inserted properly.
0 1 1 0	Processor Initialization This will show information regarding the processor (like brand name, system bus, etc...)	***
0 1 1 1	Testing RTC (Real Time Clock)	Low Lithium Battery
1 0 0 0	Initializing Video Interface This will start detecting CPU clock, checking type of video onboard. Then, detect and initialize the video adapter	***
1 0 0 1	BIOS Sign On This will start showing information about Logo, processor brand name, etc.....	***
1 0 1 0	Testing Base and Extended Memory Testing base memory from 240K to 640K and extended memory above 1MB using various patterns.	***
1 0 1 1	Assign Resource to all ISA	***
1 1 0 0	Initializing Hard Drive Controller This will initialize IDE drive and controller	Check IDE cable for proper installation
1 1 0 1	Initializing Floppy Drive Controller This will initialize Floppy Drive and controller	System D-LED will hang here The Floppy Drive Cable might not be installed properly
1 1 1 0	Boot Attempt This will set low stack and boot via INT19h.	***
1 1 1 1	Operating System Booting.	***

1 = GREEN 0 = RED

*** Check local Vendor for possible internal mainboard problem.

2.29 Front Panel Connector: J7

The mainboard provides a **Front Panel** connector.

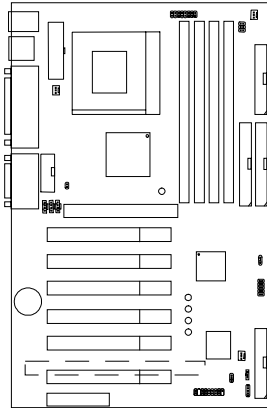

Pin Definition:

11-13 pin

Short 11-13 pin to disable Onboard Codec.

13-15 pin

Short 13-15 pin to enable Onboard Codec.

Smart LED Voice (optional)

Choose between English or Chinese Language.

Open: English

Short: Chinese

Smart LED Voice Speaker (optional)

Connect a Chassis Speaker to this 4 pin connector for Smart LED voice.

Speaker Output

Short 6-8 pin to activate AC97_SPKR

Short 8-10 pin to activate onboard Buzzer.

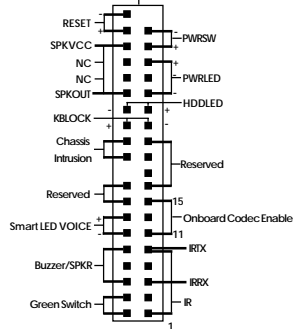

Chapter 3

AWARD® BIOS SETUP

Award® BIOS ROM has a built-in Setup program that allows users to modify the basic system configuration. This type of information is stored in battery-backed RAM (CMOS RAM), so that it retains the Setup information when the power is turned off.

3.1 Entering Setup

Power on the computer and press immediately to allow you to enter Setup. The other way to enter Setup is to power on the computer. When the below message appears briefly at the bottom of the screen during the POST (Power On Self Test), press key or simultaneously press <Ctrl>, <Alt>, and <Esc> keys.

TO ENTER SETUP BEFORE BOOT, PRESS <CTRL-ALT-ESC>
OR KEY

If the message disappears before you respond and you still wish to enter Setup, restart the system to try again by turning it OFF then ON or pressing the “RESET” button on the system case. You may also restart by simultaneously pressing <Ctrl>, <Alt>, and <Delete> keys. If you do not press the keys at the correct time and the system does not boot, an error message will be displayed and you will again be asked to,

PRESS <F1> TO CONTINUE, <CTRL-ALT-ESC>
OR TO ENTER SETUP

3.2 Getting Help

Main Menu

The on-line description of the highlighted setup function is displayed at the bottom of the screen.

Status Page Setup Menu/Option Page Setup Menu

Press F1 to pop up a small help window that describes the appropriate keys to use and the possible selections for the highlighted item. To exit the Help Window, press <Esc>.

Advanced Chipset Features

Use this menu to change the values in the chipset registers and optimize your system's performance.

Integrated Peripherals

Use this menu to specify your settings for integrated peripherals.

Power Management Setup

Use this menu to specify your settings for power management.

PnP/PCI Configuration

This entry appears if your system supports PnP/PCI.

PC Health Status

This entry shows your PC health status.

Frequency/Voltage Control

Use this menu to specify your settings for frequency/voltage control.

Load Fail-Safe Defaults

Use this menu to load the BIOS default values for the minimal/stable performance for your system to operate.

Load Optimized Defaults

Use this menu to load the BIOS default values that are factory settings for optimal performance system operations.

Supervisor/User Password

Use this menu to set User and Supervisor Passwords.

Save & Exit Setup

Save CMOS value changes to CMOS and exit setup.

Exit Without Saving

Abandon all CMOS value changes and exit setup.

3.4 Standard CMOS Setup

The items in Standard CMOS Setup Menu are divided into 10 categories. Each category includes no, one or more than one setup items. Use the arrow keys to highlight the item and then use the <PgUp> or <PgDn> keys to select the value you want in each item.

CMOS Setup Utility - Copyright(C) 1984-2000 Award Software
Standard CMOS Setup

Date(mm:dd:yy):	Fri, Feb 28,1999	Item Help
Time(hh:mm:ss):	00:00:00	
IDE Primary Master	Press Enter 2557MB	Menu Level >
IDE Primary Slave	Press Enter None	
IDE Secondary Master	Press Enter None	
IDE Secondary Slave	Press Enter None	
Drive A	1.44M, 3.5in.	
Drive B	None	
Video	EGA/VGA	
Halt On	All Errors	
Based Memory	640K	
Extended Memory	64512K	
Total Memory	65536K	
↑↓ → ← Move Enter:Select +/-/PU/PD:Value F10:Save ESC:Exit F1:General Help F5:Previous Values F6:Fail-safe defaults F7:Optimized Defaults		

Date

The date format is <day><month> <date> <year>.

Day	Day of the week, from Sun to Sat, determined by BIOS. Read-only.
month	The month from Jan. through Dec.
date	The date from 1 to 31 can be keyed by numeric function keys.
year	The year, depends on the year of the BIOS

Time

The time format is <hour> <minute> <second>.

PrimaryMaster/PrimarySlave**SecondaryMaster/Secondary Slave**

Press PgUp/<+> or PgDn/<-> to select Manual, None, Auto type.

Note that the specifications of your drive must match with the drive table. The hard disk will not work properly if you enter improper information for this category. If your hard disk drive type is not matched or listed, you can use Manual to define your own drive type manually.

If you select Manual, related information is asked to be entered to the following items. Enter the information directly from the keyboard. This information should be provided in the documentation from your hard disk vendor or the system manufacturer.

If the controller of HDD interface is SCSI, the selection shall be
“None”.

If the controller of HDD interface is CD-ROM, the selection shall be
“None”.

Access Mode	The settings are Auto, Normal, Large,LBA.
Cylinder	number of cylinders
Head	number of heads
Precomp	write precom
Landing Zone	landing zone
Sector	number of sectors

3.5 Advanced BIOS Features

CMOS Setup Utility - Copyright(C) 1984-2000 Award Software
Advanced BIOS Features

Anti-Virus Protection	Disabled	Item Help
CPU Internal Cache	Enabled	
External Cache	Enabled	Menu Level >
CPU L2 Cache ECC Checking	Enabled	
Processor Number Feature	Enabled	
Quick Power On Self Test	Disabled	
First Boot device	Floppy	
Second Boot device	HDD-0	
Third Boot device	LS/Zip	
Fourth Boot device	Disabled	
Swap Floppy Drive	Disabled	
Boot Up Floppy Seek	Disabled	
Boot Up Numlock Status	Off	
Gate A20 Option	Fast	
Typeomatic Rate Setting	Disabled	
Typeomatic Rate (Chars/Sec)	6	
Typeomatic Delay (Msec)	250	
Security Option	Setup	
OS Select for DRAM > 64MB	Non-OS2	
HDD S.M.A.R.T. Capability	Disabled	
Report No FDD for Win 95	No	
↑ ↓ → ← Move Enter:Select +/-/PU/PD:Value F10:Save ESC:Exit F1:General Help F5:Previous Values F6:Fail-safe defaults F7:Optimized Defaults		

Anti-Virus Protection

Allows you to choose the VIRUS Warning feature for IDE Hard Disk boot sector protection. If this function is enabled and someone attempt to write data into this area, BIOS will show a warning message on screen and alarm beep.

Disable(default) No warning message to appear when anything attempts to access the boot sector or hard disk partition table.

Enable Activates automatically when the system boots up causing a warning message to appear when anything attempts to access the boot sector of hard disk partition table.

CPU Internal Cache

The default value is Enabled.

Enabled (default) Enable cache

Disabled Disable cache

Note: The internal cache is built in the processor.

External Cache

Choose Enabled or Disabled. This option enables the level 2 cache memory.

CPU L2 Cache ECC Checking

Choose Enabled or Disabled. This option enables the level 2 cache memory ECC(error check correction).

Processor Number Feature

This option is for Pentium® III processor. During Enabled, this will check the CPU Serial number. Disabled this option if you don't want the system to know the Serial number.

Quick Power On Self Test

This category speeds up Power On Self Test (POST) after you power on the computer. If this is set to Enabled, BIOS will shorten or skip some check items during POST.

Enabled Enable quick POST

Disabled (default) Normal POST

First/Second/Third/Fourth Boot Device

The BIOS attempts to load the operating system from the devices in the sequence selected in these items. The settings are Floppy, LS/ZIP, HDD-0/HDD-1/HDD-2/HDD-3, SCSI, CDROM, LAN, and Disabled.

Swap Floppy Drive

Switches the floppy disk drives between being designated as A and B. Default is Disabled.

Boot Up Floppy Seek

During POST, BIOS will determine if the floppy disk drive installed is 40 or 80 tracks. 360K type is 40 tracks while 760K, 1.2M and 1.44M are all 80 tracks.

Boot Up NumLock Status

The default value is On.

On (default) Keypad is numeric keys.

Off Keypad is arrow keys.

Gate A20 Option

Normal The A20 signal is controlled by keyboard controller or chipset hardware.

Fast(default) The A20 signal is controlled by port 92 or chipset specific method.

Typematic Rate Setting

Key strokes repeat at a rate determined by the keyboard controller. When enabled, the typematic rate and typematic delay can be selected. The settings are: Enabled/Disabled.

Typematic Rate (Chars/Sec)

Sets the number of times a second to repeat a key stroke when you hold the key down. The settings are: 6, 8, 10, 12, 15, 20, 24, 30.

Typematic Delay (Msec)

Sets the delay time after the key is held down before it begins to repeat the keystroke. The settings are: 250, 500, 750, 1000.

Security Option

This category allows you to limit access to the system and Setup, or just to Setup.

- | | |
|-----------------------|---|
| System | The system will not boot and access to Setup will be denied if the correct password is not entered at the prompt. |
| Setup(default) | The system will boot, but access to Setup will be denied if the correct password is not entered at the prompt. |

OS Selection for DRAM > 64MB

Allows OS2® to be used with > 64 MB of DRAM. Settings are Non-OS/2 (default) and OS2. Set to OS/2 if using more than 64MB and running OS/2®.

HDD S.M.A.R.T Capability

This item allows you to Enabled or Disabled the HDD S.M.A.R.T (Self-Monitoring Analysis and Reporting Technology) Capability. The default setting is Disabled.

Report No FDD For Win 95

Whether report no FDD for Win 95 or not. The settings are: Yes, No.

3.6 Advanced Chipset Features

The Advanced Chipset Features Setup option is used to change the values of the chipset registers. These registers control most of the system options in the computer.

Choose the “ADVANCED CHIPSET FEATURES” from the Main Menu and the following screen will appear.

CMOS Setup Utility - Copyright(C) 1984-2000 Award Software
Advanced Chipset Features

SDRAM CAS Latency Time	3	Item Help
SDRAM Cycle Time Tras/Trc	6/8	
SDRAM RAS-to-CAS Delay	1	Menu Level >
SDRAM RAS Precharge Time	3	
System BIOS Cacheable	Disabled	
Video BIOS Cacheable	Disabled	
Memory Hole at 15M-16M	Disabled	
CPU Latency Timer	Disabled	
Delayed Transaction	Disabled	
On-Chip Video Window Size	64MB	
AGP Graphics Aperture Size	64MB	
System Memory Frequency	Auto	
Onboard Display Cache Setting		
CAS# Latency	3	
Paging Mode Control	Open	
RAS-to-CAS Override	by CAS#LT	
RAS# Timing	Fast	
RAS# Precharge Timing	Fast	
↑↓ →← Move Enter:Select +/-/PU/PD:Value F10:Save ESC:Exit F1:General Help F5:Previous Values F6:Fail-safe defaults F7:Optimized Defaults		

Note: Change these settings only if you are familiar with the chipset.

SDRAM CAS latency Time

When synchronous DRAM is installed, the number of clock cycles of CAS latency depends on the DRAM timing. The settings are: 2 and 3.

SDRAM Cycle Time Tras/Trc

Select the number of SCLKs for an access cycle. The settings are: 5/7 and 6/8.

SDRAM RAS-to-CAS Delay

This field lets you insert a timing delay between the CAS and RAS strobe signals, used when DRAM is written to, read from, or refreshed. *Fast* gives faster performance; and *Slow* gives more stable performance. This field applies only when synchronous DRAM is installed in the system. The settings are: 2 and 3.

SDRAM RAS Precharge Time

If an insufficient number of cycles is allowed for the RAS to accumulate its charge before DRAM refresh, the refresh may be incomplete and the DRAM may fail to retain data. *Fast* gives faster performance; and *Slow* gives more stable performance. This field applies only when synchronous DRAM is installed in the system. The settings are: 2 and 3.

System BIOS Cacheable

Selecting *Enabled* allows caching of the system BIOS ROM at F0000h-FFFFFh, resulting in better system performance. However, if any program writes to this memory area, a system error may result. The settings are: Enabled and Disabled.

Video BIOS Cacheable

Select Enabled allows caching of the video BIOS , resulting in better system performance. However, if any program writes to this memory area, a system error may result. The settings are: Enabled and Disabled.

Memory Hole At 15M-16M

You can reserve this area of system memory for ISA adapter ROM. When this area is reserved, it cannot be cached. The user information of peripherals that need to use this area of system memory usually discusses their memory requirements. The settings are: Enabled and Disabled.

CPU Latency Timer

During Enabled, A deferrable CPU cycle will only be Deferred after it has been in a Snoop Stall for 31 clocks and another ADS# has arrived. During Disabled, A deferrable CPU cycle will be Deferred immediately after the GMCH receives another ADS#.

Delayed Transaction

The chipset has an embedded 32-bit posted write buffer to support delay transactions cycles. Select *Enabled* to support compliance with PCI specification version 2.1. The settings are: Enabled and Disabled.

On-Chip Video Window Size

This option allows the user to set the on-chip video window size for VGA driver use.

AGP Graphics Aperture Size

This option determines the effective size of the graphics aperture used in the particular PAC configuration. The AGP aperture is memory-mapped, while graphics data structure can reside in a graphics aperture. The aperture range should be programmed as not cacheable in the processor cache, accesses with the aperture range are forwarded to the main memory, then PAC will translate the original issued address via a translation table that is maintained on the main memory. The option allows the selection of an aperture size of 32MB, 64MB.

System Memory Frequency

Select the Onboard Display Cache frequency. The settings are 100MHz, 133MHz or Auto.

Onboard Display Cache Setting (optional)

CAS# Latency

The number of clock cycles of CAS# Latency depends on the Onboard Display cache timing. The settings are: 2 and 3.

Paging Mode Control

Select the paging mode control. The settings are: Open and Close.

RAS-to-CAS Override

This item allows you to insert a timing delay between the CAS and RAS strobe signals, used when Onboard display cache is written to, read from, or refreshed. During by CAS# LT, this will depend on the Onboard Display Cache CAS# Latency setting. During Override (2), RAS-to-CAS time=2.

RAS# Timing

This option controls RAS# active to Precharge, and refresh to RAS# active delay (in local memory clocks).

Slow RAS# to precharge (t_{RAS})=7, refresh to RAS# act (t_{RC}) = 10

Fast RAS# to precharge (t_{RAS})=5, refresh to RAS# act (t_{RC}) = 8

RAS# Precharge Timing

This item controls RAS# precharge (in local memory clocks)

Slow RAS# Precharge Time=3

Fast RAS# Precharge Time=2

3.7 Integrated Peripherals

CMOS Setup Utility - Copyright(C) 1984-2000 Award Software
Integrated Peripherals

OnChip Primary PCI IDE	Enabled	Item Help
OnChip Secondary PCI IDE	Enabled	
IDE Primary Master PIO	Auto	Menu Level >
IDE Primary Slave PIO	Auto	
IDE Secondary Master PIO	Auto	
IDE Secondary Slave PIO	Auto	
IDE Primary Master UDMA	Auto	
IDE Primary Slave UDMA	Auto	
IDE Secondary Master UDMA	Auto	
IDE Secondary Slave UDMA	Auto	
USB Controller	Enabled	
USB Keyboard Support	Disabled	
Init Display First	PCI Slot	
AC97 Audio	Auto	
Audio Multi-Channel	Disabled	
IDE HDD Block Mode	Enabled	
Keyboard Power On	Disabled	
Power On Function	Button Only	
KB Power On Password	Enter	
Hot Key Power On	Ctrl-F1	
Onboard FDC Controller	Enabled	
Onboard Serial Port 1	3F8/IRQ4	
Onboard Serial Port 2	2F8/IRQ3	
↑ ↓ → ← Move Enter:Select +/-/PU/PD=Value F10:Save ESC:Exit F1:General Help F5:Previous Values F6:Fail-safe defaults F7:Optimized Defaults		

UART Mode Select	Normal
RxD, TxD Active	Hi, Lo
IR Transmission Delay	Enabled
UR2 Duplex Mode	Half
USE IR Pins	IR-Rx2Tx2
Onboard Parallel Port	378/IRQ7
Parallel Port Mode	SPP
EPP Mode Select	EPP 1.7
ECP Mode use UDMA	3
PWRON After PWR-Fail	Off
Game Port Address	201
Midi Port Address	330
Midi Port IRQ	10
Power Status LED	Single

OnChip Primary/Secondary PCI IDE

The integrated peripheral controller contains an IDE interface with support for two IDE channels. Select *Enabled* to activate each channel separately. The settings are: Enabled and Disabled.

IDE Primary/Secondary Master/Slave PIO

The four IDE PIO (Programmed Input/Output) fields let you set a PIO mode (0-4) for each of the four IDE devices that the onboard IDE interface supports. Modes 0 through 4 provide successively increased performance. In Auto mode, the system automatically determines the best mode for each device. The settings are: Auto, Mode 0, Mode 1, Mode 2, Mode 3, Mode 4.

IDE Primary/Secondary Master/Slave UDMA

Ultra DMA/33 implementation is possible only if your IDE hard drive supports it and the operating environment includes a DMA driver (Windows 95 OSR2 or a third-party IDE bus master driver). If your hard drive and your system software both support Ultra DMA/33, Ultra DMA/66 and Ultra DMA/100 select Auto to enable BIOS support. The settings are: Auto, Disabled.

USB Controller

Select *Enabled* if your system contains a Universal Serial Bus (USB) controller and you have USB peripherals. The settings are: Enabled, Disabled.

USB Keyboard Support

Select *Enabled* if your system contains a Universal Serial Bus (USB) controller and you have a USB keyboard. The settings are: Enabled, Disabled.

Init Display First

This item allows you to decide to activate whether PCI Slot or on-chip VGA first. The settings are: PCI Slot, Onboard.

AC97 Audio

This item allows you to decide to enable/disable the 815 chipset family to support AC97 Audio.

Audio Multi-Channel (optional)

This item allows you to Enabled or Disabled the Audio Multi-Channel audio speaker.

IDE HDD Block Mode

Block mode is also called block transfer, multiple commands, or multiple sector read/write. If your IDE hard drive supports block mode (most new drives do), select Enabled for automatic detection of the optimal number of block read/writes per sector the drive can support. The settings are: Enabled, Disabled.

Keyboard Power on Function

This function allows you to Enabled or Disabled the Keyboard Power On. The default setting is Disabled.

Power On Function

This function allows you to select the item to power on the system. The settings are : Button Only, Mouse Left, Mouse Right, Password, Hotkey, keyboard 98.

Onboard FDC Controller

Select Enabled if your system has a floppy disk controller (FDD) installed on the system board and you wish to use it. If you install add-on FDC or the system has no floppy drive, select Disabled in this field. The settings are: Enabled and Disabled.

Onboard Serial Port 1/Port 2

Select an address and corresponding interrupt for the first and second serial ports. The settings are: 3F8/IRQ4, 2E8/IRQ3, 3E8/IRQ4, 2F8/IRQ3, Disabled, Auto.

UART Mode Select

This item allows you to determine which InfraRed(IR) function of the onboard I/O chip, this functions uses.

Onboard Parallel Port

Disabled
(3BCH/IRQ7)/
(278H/IRQ5)/
(378H/IRQ7)

There is a built-in parallel port on the on-board Super I/O chipset that provides Standard, ECP, and EPP features. It has the following options:

Disable
3BCH/IRQ7 Line Printer port 0
278H/IRQ5 Line Printer port 2
378H/IRQ7 Line Printer port 1

Onboard Parallel Mode

SPP : Standard Parallel Port
EPP : Enhanced Parallel Port
ECP : Extended Capability Port

**SPP/EPP/ECP/
ECP+EPP**

To operate the onboard parallel port as Standard Parallel Port only, choose "SPP." To operate the onboard parallel port in the EPP modes simultaneously, choose "EPP." By choosing "ECP", the onboard parallel port will operate in ECP mode only. Choosing "ECP + EPP" will allow the onboard parallel port to support both the ECP and EPP modes simultaneously. The ECP mode has to use the DMA channel, so choose the onboard parallel port with the ECP feature. After selecting it, the following message will appear: "ECP Mode Use DMA" At this time, the user can choose between DMA

channels 3 or 1. The onboard parallel port is EPP Spec. compliant, so after the user chooses the onboard parallel port with the EPP function, the following message will be displayed on the screen: “EPP Mode Select.” At this time either EPP 1.7 spec. or EPP 1.9 spec. can be chosen.

PWRON After PWR-FAIL

This option will determine how the system will power on after a power failure.

Game Port Address/Midi Port Address

This will determine which Address the Game Port/Midi Port will use.

Power Status LED

This item determines which state the Power LED will use. The settings are Blinking, Dual, and Single. During blinking, the power LED will blink when the system enters the suspend mode. When the mode is in Dual, the power LED will change its color. Choose the single and the power LED will always remain lit.

3.8 Power Management Setup

The Power Management Setup allows you to configure you system to most effectively save energy while operating in a manner consistent with your own style of computer use.

CMOS Setup Utility - Copyright(C) 1984-2000 Award Software
Power Management Setup

ACPI Function	Enabled	Item Help
ACPI Suspend Type	S1(POS)	
Power Management	User Define	Menu Level >
Video Off Method	DPMS	
Video Off In Suspend	Yes	
Suspend Type	Stop Grant	
Modem Use IRQ	3	
Suspend Mode	Disabled	
HDD Power Down	Disabled	
Soft-Off by PWR-BTTN	Instant-Off	
Wake-Up by PCI Card	Disabled	
Power On by Ring	Disabled	
Wake-Up on LAN	Disabled	
USB KB Wake-Up from S3	Disabled	
CPU Thermal-Throtting	62.57%	
Resume By Alarm	Disabled	
Date(of Month) Alarm	0	
Date(hh:mm:ss)	0 0 0	
Reload Global Timer Events		
Primary IDE 0	Disabled	
Primary IDE 1	Disabled	
Secondary IDE 0	Disabled	
Secondary IDE 1	Disabled	
FDD, COM, LPT Port	Disabled	
PCI PIRQ[A-D]#	Disabled	
↓ → ← Move Enter:Select +/-/PU/PD:Value F10:Save ESC:Exit F1:General Help F5:Previous Values F6:Fail-safe defaults F7:Optimized Defaults		

ACPI Function

This item allows you to Enabled/Disabled the Advanced Configuration and Power Management (ACPI). The settings are Enabled and Disabled.

ACPI Suspend Type

This item will set which ACPI suspend type will be used.

S1 (POS)

The S1 sleeping state is low wake-up latency sleeping state. In this state, no system context is lost (CPU or chip set) and hardware maintains all system context.

S3 (STR)

The S3 state is a low wake-up latency sleeping state where all system context is lost except system memory. CPU, cache, and chipset context are lost in this state. Hardware maintains memory context and restores some CPU and L2 configuration context.

Power Management

This category allows you to select the type (or degree) of power saving and is directly related to the following modes:

1. Suspend Mode
2. HDD Power Down

There are three selections for Power Management, two of which have fixed mode settings.

Min. Power Saving	Minimum power management. Suspend Mode = 1 hr., and HDD Power Down = 15 min.
Max. Power Saving	Maximum power management — Suspend Mode = 1 min., and HDD Power Down = 1 min.
User Defined (default)	Allows you to set each mode individually. When not disabled, each of the ranges are from 1 min. to 1 hr. except for HDD Power Down which ranges from 1 min. to 15 min. and disable.

Video Off Method

This determines the manner in which the monitor is blanked.

V/HSYNC+Blank	This selection will cause the system to turn off the vertical and horizontal synchronization ports and write blanks to the video buffer.
Blank Screen	This option only writes blanks to the video buffer.
DPMS (default)	Initial display power management signaling.

Video Off In Suspend

This determines the manner in which the monitor is blanked.
The settings are: Yes and No.

Suspend Type

Select the Suspend Type. The settings are: PWRON Suspend, Stop Grant.

Modem Use IRQ

This determines the IRQ in which the MODEM can use.
The settings are: 3, 4, 5, 7, 9, 10, 11, NA.

Suspend Mode

When enabled and after the set time of system inactivity, all devices except the CPU will be shut off. The settings are: 1/2/4/8/12/20/30/40 Min, 1 Hour, and Disabled.

HDD Power Down

When enabled and after the set time of system inactivity, the hard disk drive will be powered down while all other devices remain active.
The settings are: 1/2/3/4/5/6/7/8/9/10/11/12/13/14/15Min and Disabled.

Soft-Off by PWR-BTTN

Pressing the power button for more than 4 seconds forces the system to enter the Soft-Off state. The settings are: Delay 4 Sec, Instant-Off.

Wake-Up by PCI Card

This will enable the system to wake up through PCI Card peripheral.
The settings are : Enabled and Disabled.

Power On by Ring

During Disabled, the system will ignore any incoming call from the modem. During Enabled, the system will boot up if there's an incoming call from the modem.

Wake-Up on LAN

To use this function, you need a LAN add-on card which support power on functions. It should also support the wake-up on LAN jumper (JWOL1).

Enabled	Wake up on LAN supported.
Disabled	Wake up on LAN not supported.

USB KB Wake-Up From S3

This option is used to Enabled/Disabled USB keyboard wake up with suspend to RAM.

CPU Thermal-Throttling

Select the CPU THRM-Throttling rate. The settings are: 12.5%, 25.0%, 37.5%, 50.0%, 62.5%, 75.0%, 87.5%.

Resume by Alarm

This function is for setting date and time for your computer to boot up. During Disabled, you cannot use this function. During Enabled, choose the Date and Time Alarm:

Date(of month) Alarm	You can choose which month the system will boot up. Set to 0, to boot every day.
Time(hh:mm:ss) Alarm	You can choose what hour, minute and second the system will boot up.

Note: If you have change the setting, you must let the system boot up until it goes to the operating system, before this function will work.

Reload Global Timer Events

Reload Global Timer events are I/O events whose occurrence can prevent the system from entering a power saving mode or can awaken the system from such a mode. In effect, the system remains alert for anything which occurs to a device which is configured as *Enabled* , even when the system is in a power down mode.

Primary IDE 0

Primary IDE 1

Secondary IDE 0

Secondary IDE 1

FDD, COM, LPT Port

PCIPIRQ[A-D]#

3.9 PnP/PCI Configuration Setup

This section describes configuring the PCI bus system. PCI, or **P**ersonal **C**omputer **I**nterconnect, is a system which allows I/O devices to operate at speeds nearing the speed the CPU itself uses when communicating with its own special components. This section covers some very technical items and it is strongly recommended that only experienced users should make any changes to the default settings.

CMOS Setup Utility - Copyright(C) 1984-2000 Award Software
PnP/PCI Configuration Setup

PNP OS Installed	No	Item Help
Reset Configuration Data	Disabled	
Resources Controlled By	Auto	Menu Level >
IRQ Resources	Press Enter	
DMA Resources	Press Enter	
PCI/VGA Palette Snoop	Disabled	
↑ ↓ → ← Move Enter:Select +/-/PU/PD:Value F10:Save ESC:Exit F1:General Help F5:Previous Values F6:Fail-safe defaults F7:Optimized Defaults		

PNP OS Installed

This item allows you to determine whether the PnP OS is installed or not. The settings are Yes or No.

Reset Configuration Data

Normally, you leave this field Disabled. Select Enabled to reset Extended System Configuration Data (ESCD) when you exit Setup if you have installed a new add-on and the system reconfiguration has caused such a serious conflict that the operating system can not boot.

The settings are: Enabled and Disabled .

Resource Controlled By

The Award Plug and Play BIOS has the capacity to automatically configure all of the boot and Plug and Play compatible devices. However, this capability means absolutely nothing unless you are using a Plug and Play operating system such as Windows®95/98. If you set this field to “manual” choose specific resources by going into each of the sub menu that follows this field (a sub menu is preceded by a “➤”). The settings are: Auto(ESCD), Manual.

IRQ Resources

When resources are controlled manually, assign each system interrupt a type, depending on the type of device using the interrupt.

DMA Resources

This sub menu can let you control the DMA resource.

PCI/VGA Palette Snoop

Leave this field at *Disabled*. The settings are Enabled, Disabled.

3.10 PC Health Status

This section shows the Status of your CPU, Fan, Warning for overall system status.

CMOS Setup Utility - Copyright(C) 1984-2000 Award Software
 PC Health Status

CPU Warning Temperature	Disabled	Item Help
Current System Temp	39°C/102°F	
Current CPU Temperature	66°C/150°F	Menu Level >
Current Top Tech. III Temp.	32°C/89°F	
Current System Fan	0RPM	
Current Power Fan	0RPM	
Current CPU FAN	5532RPM	
Vcore	1.96V	
VTT	1.48V	
3.3V	3.24V	
+5V	4.89V	
+12V	11.79V	
-12V	12.19V	
-5V	-4.53V	
VBAT(V)	3.10V	
5VSB(V)	5.37V	
Chassis Intrusion Detect	Disabled	
Shutdown Temperature	Disabled	
↑ ↓ → ← Move Enter:Select +/-/PU/PD:Value F10:Save ESC:Exit F1:General Help F5:Previous Values F6:Fail-safe defaults F7:Optimized Defaults		

CPU Warning Temperature

During Enabled, this will warn the user when the CPU temperature reach a certain temperature.

Current System Temp/Current CPU Temperature/Current Top Tech. III Temp/Current System Fan (optional)/Power Fan (optional)/Cpu Fan/Vcore/VTT/3.3V/+5V/+12V/-12V/-5V/VBAT(V)/5VSB(V)

This will show the CPU/FAN/System voltage chart and FAN Speed.

Chassis Intrusion Detect

Set this option to Enabled, Reset, or Disabled the chassis intrusion detector. During Enabled, any intrusion on the system chassis will be recorded. The next time you turn on the system, it will show a warning message. To be able to clear those warning, choose reset. After clearing the message it will go back to Enabled.

Shutdown Temperature

This option is for setting the Shutdown temperature level for the processor. When the processor reach the temperature you set, this will shutdown the system.

3.11 Frequency/Voltage Control

This section is for setting CPU Frequency/Voltage Control.

CMOS Setup Utility - Copyright(C) 1984-2000 Award Software
Frequency/Voltage Control

Auto Detect DIMM/PCI Clk	Enabled	Item Help
CPU Clock/Spread Spectrum	Enabled	
Clock By Slight Adjust	133	Menu Level >
CPU Clock Ratio	Auto	
DRAM Voltage Adjust	Default	
Adjust CPU Voltage	Default	
↑↓ →← Move Enter:Select +/-/PU/PD:Value F10:Save ESC:Exit F1:General Help F5:Previous Values F6:Fail-safe defaults F7:Optimized Defaults		

Auto Detect DIMM/PCI CLK

This item allows you to enable/disable auto detect DIMM/PCI Clock.
The settings are: Enabled, Disabled.

CPU Clock/Spread Spectrum

This item allows you to set the CPU Clock/Spread Spectrum.

Clock By Slight Adjust

This item allows you to select the CPU clock from 133MHz to 166MHz or 100MHz to 133MHz depending on the CPU host clock.

DRAM Voltage Option

This option is used to set the DIMM voltage. The settings are 3.3V/3.4V/3.5V/3.6V. The default setting is 3.3V.

Adjust CPU Voltage

This function is used to adjust the CPU voltage. During overclocking, the processor might get unstable. Try adjusting the CPU voltage to lessen the heat, generated by the CPU voltage.

Note: We do not guarantee that the mainboard or other components will work properly after overclocking.

3.12 Load Fail-Safe/Optimized Defaults

Load Fail-Safe Defaults

When you press <Enter> on this item, you get a confirmation dialog box with a message similar to:

Load Fail-Safe Defaults (Y/N) ? N

Pressing 'Y' loads the BIOS default values for the most stable, minimal-performance system operations.

Load Optimized Defaults

When you press <Enter> on this item, you get a confirmation dialog box with a message similar to:

Load Optimized Defaults (Y/N) ? N

Pressing 'Y' loads the default values that are factory settings for optimal performance system operations.

3.13 Set Supervisor/User Password

You can set either supervisor or user password, or both of them. The differences are:

Supervisor password : Can enter and change the options of the setup menus.

User password : Can only enter but do not have the right to change the options of the setup menus. When you select this function, the following message will appear at the center of the screen to assist you in creating a password.

ENTER PASSWORD:

Type the password, up to eight characters in length, and press <Enter>. The password typed now will clear any previously entered password from CMOS memory. You will be asked to confirm the password. Type the password again and press <Enter>. You may also press <Esc> to abort the selection and not enter a password.

To disable a password, just press <Enter> when you are prompted to enter the password. A message will confirm the password will be disabled. Once the password is disabled, the system will boot and you can enter Setup freely.

PASSWORD DISABLED.

When a password has been enabled, you will be prompted to enter it every time you try to enter Setup. This prevents an unauthorized person from changing any part of your system configuration.

Additionally, when a password is enabled, you can also require the BIOS to request a password every time your system is rebooted. This would prevent unauthorized use of your computer.

You determine when the password is required within the BIOS Features Setup Menu and its Security option. If the Security option is set to “System”, the password will be required both at boot and at entry to Setup. If set to “Setup”, prompting only occurs when trying to enter Setup.

Chapter 4

INTEL® 815 INTEGRATED GRAPHICS CONTROLLER

1. Overview

The Intel® 815 Chipset extends Intel's graphics capabilities into the value PC segment by incorporating 2D and 3D capabilities with the memory controller, to provide the industry with complete graphics offerings for every computing segment.

1.1 Intel® 815 Chipset

- Support 4MB Display Cache (optional)
- Support AGP 2X/4X BUS
- 2D & 3D Graphics Accelerator

1.2 System Requirements

This section describes system requirements for the VGA Driver installation and Usage.

Computer	Intel® Celeron™/ Pentium® III (FC-PGA) processor or higher
Monitor	VGA Support, minimum 640x480 resolution
Operating system	DOS 5.0 or higher, Windows® 95/98, Windows® NT 3.51 or 4.0, or OS/2®
CD-ROM	Double Speed or Higher
Chipset	Intel® 815 chipset
VGA BIOS	Version 00.23 or Higher

2. Intel® 815 VGA Driver Setup & Usage Procedures

Insert the CD-title into your CD-ROM drive. This CD will auto-run. This will display installation for VGA driver and sound driver, Intel 815/820 INF Update (only for Windows 95/98) and Trend PC-cillin 98. Just click the button for automatic installation for VGA driver.

2.1 Windows® 95/98

If you start Windows® 95/98, this will automatically detect this hardware onboard “Standard PCI Graphics Adapter (VGA)”. You need to click “Next”, then “Finish”. Do not click on the “Cancel”. The driver need these ID.

Note: Before installing the Intel 815 VGA Driver, you need to install the Intel 815/820 INF update first.

2.1-1 Display Driver Installation Procedure:

- Step 1:** Insert the provided CD_ROM disk into the CD-ROM drive.
 - Step 2:** Look for the CD_ROM drive, double click on the CD_ROM icon. This will show the setup screen.
 - Step 3:** Click on “Intel 815 VGA Driver” icon.
 - Step 4:** This will show an installation menu.
 - Step 5:** Click on “Display Drivers”.
 - Step 6:** Click “OK”.
 - Step 7:** This will copy the VGA drivers into the hard drive.
 - Step 8:** A message will appear stating you must restart the Windows® 95/98 system, select **yes** to restart.
 - Step 9:** After restarting, Windows® 95/98 will show a new display setting.
-

2.2 Windows® NT 4.0

You need to install Windows® NT “Service Pack 3” or higher, before you install Windows® NT driver.

2.2-1 Display Driver Installation Procedure:

- Step 1:** Click **Start** menu and select **Control Panel** from **Settings** group.
- Step 2:** Select **Display** icon.
- Step 3:** Select **Settings** on the Display Properties.
- Step 4:** Select **Display Type**.
- Step 5:** Select **Change** from the **Adapter Type** Area.
- Step 6:** Select **Have Disk** of Change Display.
- Step 7:** Insert the **CD-Title Disk** into CD-ROM Drive.
- Step 8:** When the Install from Disk dialog box appears, look for your CD-ROM drive :**\SVGA\Intel\815\NT4\WINNT4**
- Step 9:** When the **Change Display** dialog box appears, click **OK**.
- Step 10:** When the Third-party Drivers dialog box appears, click **Yes**.
A message will appear stating that the drivers were successfully installed. Click **OK**. You must now restart Windows® NT 4.0.

Note: You can also use CD autorun to install the VGA NT driver.

2.2-2 Changing resolution, color depth, and refresh rate:

- Step 1:** Click **Start** menu and select **Control Panel** from **Settings** group.
- Step 2:** Select **Display** icon.
- Step 3:** Select **Settings**.
- Step 4:** Select Color Palette to change between 256 color, 65536 colors, and 16777216 colors.
- Step 5:** To select desktop resolution size, go to the Desktop area and use the slide bar to change resolution from 640x480, 800x600, 1024x768, 1152x864, 1280x1024, to 1600x1200.
- Step 6:** Select Test to test the resolution. If the display test screen was good, then select Yes when the Testing Mode dialog box appears. If the display test screen was bad, then select No. Windows® NT will give you an error message.
- Step 7:** Click OK. If the display test screen was good and you select Yes, Windows® NT 4.0 will change the mode without restarting the system.

2.3 AutoCAD, OS/2 and other application. Please refer to “On-Line Manual” in the CD-ROM. You need to install the “Acrobat Reader 3.01” program first.