



Apollo/Shadowhawk

U S E R M A N U A L





System Manual

Copyright

PREMIO is a registered trademark of Premio Computer, Inc. All other brands and product names are trademarks or registered trademarks of their respective companies.

© 1997 by Premio Computer, Inc. All rights reserved.

Printed in Taiwan.

Version 2.0, September, 1997.

Disclaimers

PREMIO makes no representation or warranties, either expressed or implied, with respect to the contents of this publication and specifically disclaims the implied warranties of merchantability or fitness for a particular purpose. PREMIO shall not be liable for technical or editorial errors or omissions in this publication, or for incidental or consequential damages resulting from the furnishing, performance, or use of this publication. We reserve the right to revise this publication and to make changes from time to time in its contents without notification.

Contents

GETTING STARTED	1
Setting Up.....	2
Switches and Indicators.....	3
UPGRADING	5
Opening the System Unit.....	6
Installing an Expansion Card	7
Installing Memory	8
Installing a SIMM	8
Removing a SIMM.....	9
Installing a DIMM	9
Removing a DIMM.....	10
Installing a Hard Drive.....	11
GETTING HELP.....	12
Troubleshooting	12
Monitor Does Not Work	12
Keyboard Does Not Work.....	13
Mouse Does Not Work.....	13
System Unit Problems.....	14
Hard Disk Problems	14

Warranty Service.....	15
Technical Support.....	15
PREMIO on the Internet.....	15
APPENDIX	16
Limited 3-Year Warranty.....	16
FCC Standards	18
Important Safety Instructions.....	19

Getting Started

Your PREMIO® system consists of three components:

- a mid-tower or desktop system unit
- a keyboard
- a mouse

Add your choice of monitor, and your system is ready to use.

Mid-tower system

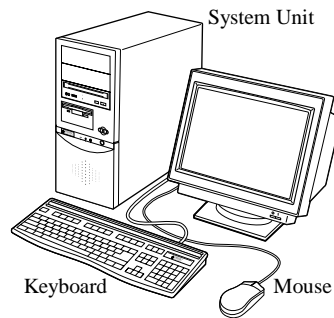

Desktop system

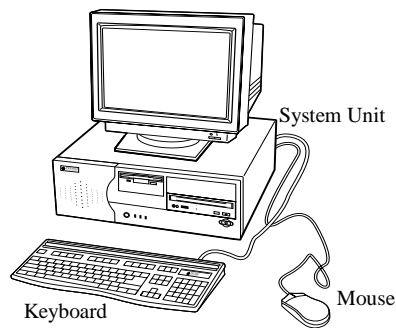

Setting Up

To set up your PREMIO system, simply connect your monitor, the mouse, the keyboard, and any additional components you want to use to the system unit.

Follow these easy steps:

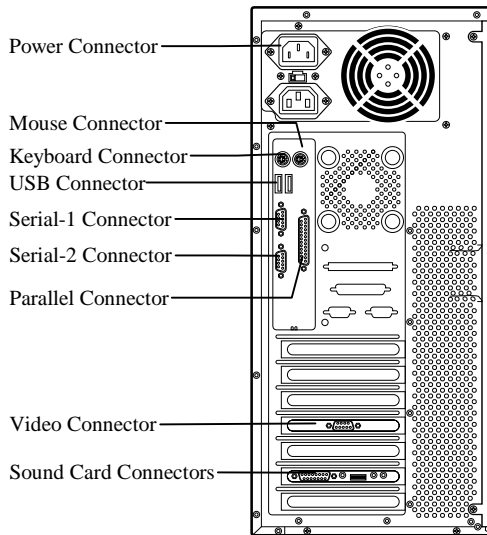

- 1 Attach your monitor's video cable to the video connector.
- 2 Attach the mouse cable to the mouse connector.
- 3 Attach the keyboard cable to the keyboard connector.
- 4 Attach the cables for any additional components, such as a printer, scanner, or modem, to the parallel, serial, or universal serial bus (USB) connector, as directed in the component's manual.
- 5 If your system is equipped for multimedia, attach your speakers and microphone to the sound card connectors.

6 Plug your monitor's power cord into a power outlet.

7 Attach the female end of the system power cord to the system unit's power connector, and then plug the other end of the cord into a power outlet.

Your PREMIO system is now ready to use. To start the system, turn on your monitor's power switch and then press the system power switch as shown on the next page.

Switches and Indicators

The system unit's front panel provides access to the CD-ROM and floppy drives, and to the system's switches and indicator lights.

The illustration below shows a mid-tower system. If you have a desktop system, turn to the illustration on the next page.

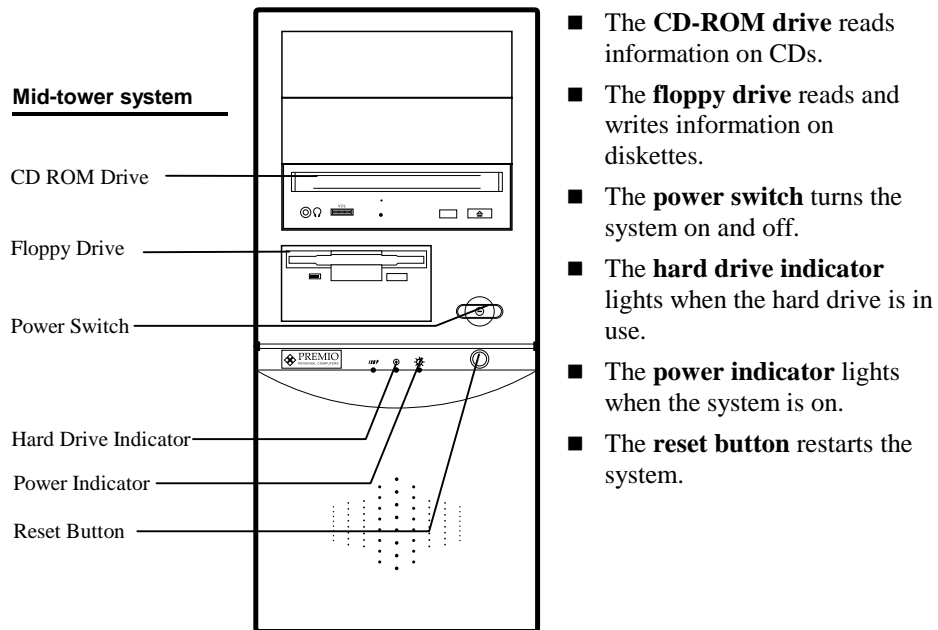

Desktop system

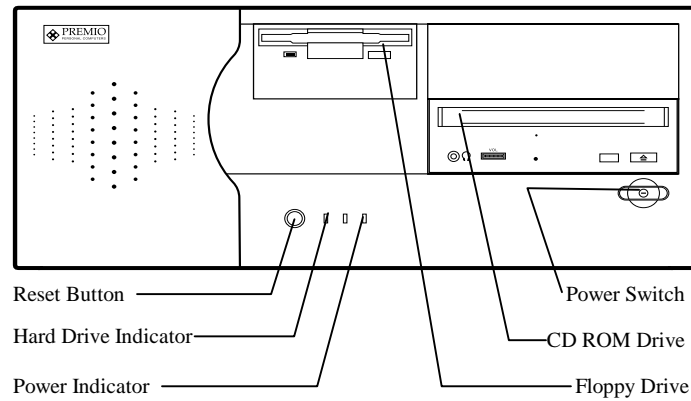

- The **reset button** restarts the system.
- The **hard drive indicator** lights when the hard drive is in use.
- The **power indicator** lights when the system is on.
- The **power switch** turns the system on and off.
- The **CD-ROM drive** reads information on CDs.
- The **floppy drive** reads and writes information on diskettes.

Upgrading

You can upgrade your PREMIO system with:

- Expansion cards
- More memory
- An additional hard drive

To install an upgrade, you must open the system unit. Before proceeding, read the important cautionary note below. Then follow the steps on the next page.

Caution! *Static discharge can cause permanent damage to internal electronic components of your computer. Always use the following precautions when working inside the system unit:*

- *Wear a grounding wrist strap (available at most electronics stores) when handling electronic components.*
- *Do not remove a component from its antistatic packaging until you are ready to install it.*
- *Keep one hand in contact with the metal system case.*

Opening the System Unit

Note *Opening the system unit could affect your warranty. Check with the dealer where you purchased your system before opening the system unit.*

To open the system unit, follow these steps

Mid-tower system

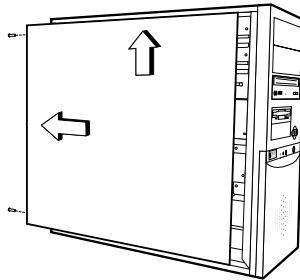

- 1** Turn off the system and unplug the power cord.
- 2** Remove the screws securing the side panel (mid-tower) or case (desktop) at the rear of the system unit.

Desktop system

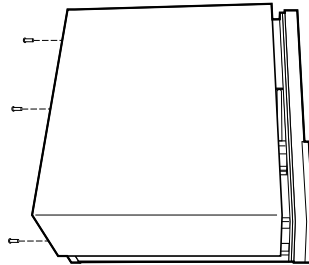

- 3** Slide the side panel or case up and to the rear, and remove it.

Installing an Expansion Card

To install an expansion card, open the system unit as described on the previous page. Then follow these steps:

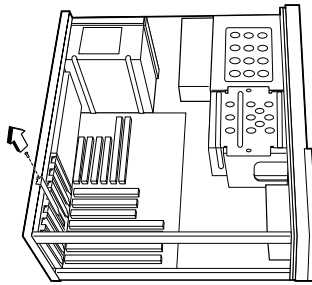

use. Save the screw to secure the expansion card.

- 1** Remove the screw securing the slot bracket cover for the expansion slot you want to

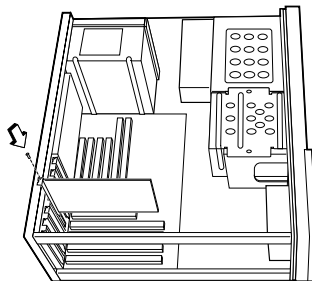

- 2** Insert the expansion card firmly into the slot, making sure it is seated completely.
- 3** Secure the card with the saved screw.

Installing Memory

Note For details on memory configuration, including the placement and type of memory to use in your system, refer to the motherboard user's manual that came with your system.

Follow these general guidelines when adding memory:

- Use only the same type of memory throughout. For example, do not mix EDO and fast page memory.
- SIMMs must be installed in pairs, and both SIMMs in the pair must be the same size and speed. For example, do not install one 16-MB and one 8-MB SIMM.

Installing a SIMM

To install a SIMM, follow these steps:

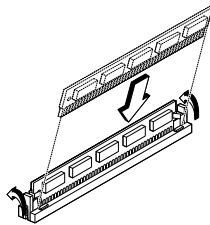

- 1 Insert the SIMM into the socket at a 45° angle. (SIMMs can be installed only one way.)
- 2 Gently press the SIMM up into a vertical position until it snaps into place. The SIMM's clips will hold it firmly at a 90° angle when it is properly installed.

Removing a SIMM

To remove a SIMM, follow these steps:

- 1 Press the holding clips on both sides of the SIMM outward to release it.

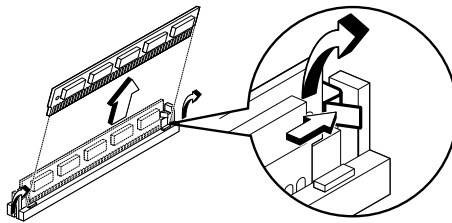

- 2 Tilt the SIMM to a 45° angle.
- 3 Pull the SIMM up and out of the socket.

Installing a DIMM

To install a DIMM, follow these steps:

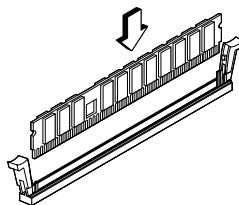

- 1 Insert the DIMM vertically into the socket. (DIMMs can fit into the slot only one way.)
- 2 Push down on the DIMM to seat it, and then raise the plastic clips at either side to lock it in place.

Removing a DIMM

To remove a DIMM, follow these steps:

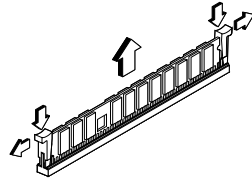

1 Push down and out on the plastic clips at either end to release them.

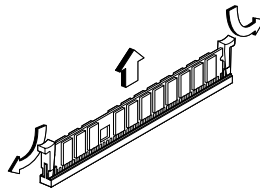

2 Pull the DIMM up and out of the socket.

Installing a Hard Drive

To install a hard drive in your system, follow these steps:

Mid-tower system

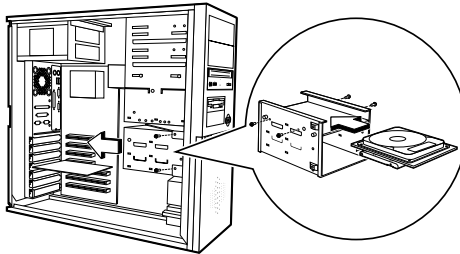

Desktop system

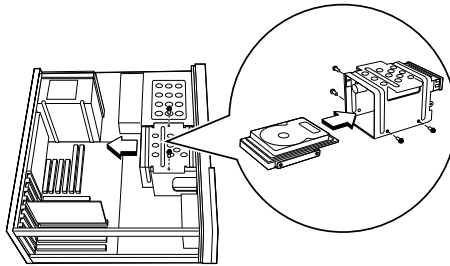

- 1 Disconnect the hard drive cable and power connector.
- 2 Remove the two screws securing the drive bay.
- 3 Slide the bay toward the rear of the system unit to remove it.
- 4 Insert the new drive into an open position in the bay and secure it with four screws.
- 5 Slide the bay back into the system unit and secure it with two screws.
- 6 Connect the cables.

Getting Help

Troubleshooting

Your PREMIO system is designed to provide years of trouble-free performance. If you have a problem with your system, first check the information in this section for a quick solution.

Monitor Does Not Work

If your monitor appears not to be working properly:

- Check that the monitor's power cable is securely attached to the monitor and to an outlet that is receiving power.
- Check that the monitor's video cable is securely attached to the monitor and to the system unit's video card connector.
- Check that the monitor's power switch is on.
- Adjust the monitor's brightness and contrast controls.
- If possible, substitute another monitor that is in good working order. If the substitute works, your monitor may need repair or replacement.

Keyboard Does Not Work

If the NumLock indicator in the upper right corner of the keyboard does not light when the system powers up, or the keyboard does not work:

- Check that the keyboard cable is securely attached to the system unit's keyboard connector.
- If possible, substitute another keyboard that is in good working order. If the substitute works, your keyboard may need replacement.

Mouse Does Not Work

If your mouse pointer does not move or moves erratically when you move the mouse:

- Check that the mouse cable is securely attached to the mouse connector on the system unit.
- Disassemble the mouse and clean the roller ball.

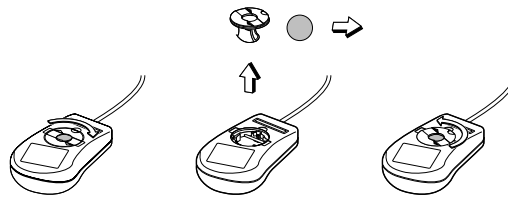

System Unit Problems

The fan inside the system unit should make a low, steady sound when operating properly. If the fan is totally silent:

- Check that the system power cord is securely attached to the back of the system unit and to a power outlet. Verify that the outlet has power.
- If possible, substitute another power cord that is in good working order. If the substitute works, replace your power cord.

If the fan makes excessive noise:

- Turn off the system, open the system unit case, and inspect the fan for any obstructions.
- Turn on the system and listen closely to the fan. If the noise comes from inside the fan housing, your power supply may need replacement.

Hard Disk Problems

Your hard disk should make a slight whirring sound when operating properly. If the disk is totally silent:

- Turn off the system, open the system unit case, and check that the power cable between the power supply and the hard disk is securely attached at both ends. If it is, your hard disk may be defective.

If the hard disk makes excessive noise:

- Turn off the system, open the system unit case, and remove the hard disk power cable connector from the hard disk. Then turn the system back on. If the noise disappears, your hard disk may be defective.
- If you have more than one hard disk, repeat the same procedure for each disk.

Warranty Service

If you have a problem with your PREMIO system that requires service during the warranty period, contact the dealer where you purchased your system. Your dealer will try to resolve the problem for you. If your dealer cannot resolve the problem, you can contact PREMIO directly at the address below.

Note *To obtain warranty service, you must provide proof of purchase, including the purchase date.*

Technical Support

You can contact PREMIO technical support at the following address:

Premio Computer, Inc.
918 Radecki Court
City of Industry, CA 91748
Telephone: 800-568-6388
Fax: 626-839-3191
Email: support@premiopc.com

PREMIO on the Internet

PREMIO maintains a web page on the Internet with the latest information on PREMIO products, updated drivers, answers to common problems, a Windows 95 troubleshooting guide, and more. Visit our web page at:

<http://www.premiopc.com>

Appendix

Limited 3-Year Warranty

Premio Computer, Inc. warrants its line of PREMIO® computer systems (hereinafter "Product") to be free from defects in material and workmanship for a period of three (3) years from the date of original purchase from Premio Computer, Inc. or a Premio Computer, Inc. authorized reseller. This warranty does not cover monitor and LCD panels, nor third-party hardware and software which has a separate manufacturer's warranty. Warranty for such third-party hardware and software, if any, is subject to the third-party's warranty policy.

PREMIO branded monitors are warranted as follows:

Three (3) year parts and labor except for CRT

One (1) year parts and labor for CRT

PREMIO branded LCD panels are warranted as follows:

One (1) year parts and labor

SERVICE UNDER WARRANTY

If this Product fails to be in good working order during this 3-year warranty period (or specific period of time as noted above), Premio Computer, Inc. will, at its option, repair or replace the Product. Repair parts and/or replacement Products may be either new or reconditioned at Premio Computer Inc.'s discretion. The limited warranty does not include service to repair damage from improper installation, abuse or modifications to the Product not approved in writing by Premio Computer, Inc. Any service repair outside the scope of this limited warranty shall be at Premio Computer, Inc.'s or its Authorized Service Provider's rates and terms in effect.

This warranty is valid only within the United States and applies only to Products which are new and in cartons which are unopened on the date of purchase.

EXCLUSIONS FROM PREMIO, INC. LIMITED WARRANTY PROGRAM

ALL OTHER EXPRESSED AND IMPLIED WARRANTIES FOR THIS PRODUCT, INCLUDING THE WARRANTIES OF MERCHANTABILITY AND FITNESS FOR A PARTICULAR PURPOSE, ARE HEREBY DISCLAIMED. IF THIS PRODUCT IS NOT IN GOOD WORKING ORDER AS WARRANTED ABOVE, PREMIO COMPUTER, INC.'S SOLE AND EXCLUSIVE REMEDY SHALL BE REPAIR OR REPLACEMENT AS STATED ABOVE. IN NO EVENT WILL PREMIO COMPUTER, INC. BE LIABLE TO THE CUSTOMER OR ANY THIRD PARTY FOR ANY DAMAGES IN EXCESS OF THE PURCHASE PRICE OF THE PRODUCT. THIS LIMITATION APPLIES TO DAMAGES OF ANY KIND INCLUDING ANY DIRECT OR INDIRECT DAMAGES, LOST PROFITS, LOST SAVINGS OR OTHER SPECIAL, INCIDENTAL, EXEMPLARY OR CONSEQUENTIAL DAMAGES WHETHER ARISING OUT OF THE USE OF OR INABILITY TO USE SUCH PRODUCT, EVEN IF PREMIO COMPUTER, INC. OR AN AUTHORIZED PREMIO COMPUTER, INC. REPRESENTATIVE OR DEALER HAS BEEN ADVISED OF THE POSSIBILITY OF SUCH DAMAGES OR OF ANY CLAIM BY ANY OTHER PARTY. SOME STATES DO NOT ALLOW THE EXCLUSION OR LIMITATION OF INCIDENTAL OR CONSEQUENTIAL DAMAGES FOR SOME PRODUCTS, SO THE ABOVE LIMITATIONS OR EXCLUSIONS MAY NOT APPLY TO YOU. PREMIO COMPUTER, INC. AUTHORIZED RESELLERS AND SERVICE PROVIDERS/PARTNERS MAY BE CHANGED, ADDED OR DELETED, WITHOUT NOTICE OR LIABILITY. PREMIO COMPUTER, INC. DISCLAIMS ANY AUTHORIZED RESELLERS AND SERVICE PROVIDER/PARTNER TO THE PROGRAM. THIS WARRANTY GIVES YOU SPECIFIC LEGAL RIGHTS AND YOU MAY ALSO HAVE OTHER RIGHTS WHICH MAY VARY FROM STATE TO STATE.

FCC Standards

The FCC (Federal Communications Commission) restricts the amount of radiation and radio frequency emissions from computing equipment.

This equipment generates and uses radio frequency energy and if not installed and used properly in strict accordance with the operation instructions, reference manuals, and the service manual, may cause interference to radio or television reception.

This equipment can be tested and found to comply with the limits for a Class B digital device pursuant to part 15 of the FCC rules. These limits are designed to provide reasonable protection against harmful interference in a residential installation. This equipment generates, uses, and can radiate radio frequency energy and, if not installed and used in accordance with the instructions, may cause harmful interference to radio communications. However, there is no guarantee that interference will not occur in a particular installation. If this equipment does cause harmful interference to radio or television reception, which can be determined by turning the equipment off and on, then the user is encouraged to try to correct the interference by one or more of the following procedures:

- Reorient or relocate the receiving antenna.
- Increase the separation between the equipment and receiver.
- Connect the equipment into an outlet on a circuit different from that to which the receiver is connected.
- Consult the dealer or an experienced radio/TV technician for help.

Important Safety Instructions

These instructions are provided by Underwriters Laboratories, Inc.

1. Read all of these instructions and save them for later reference.
2. Follow all warnings and instructions marked on the product.
3. Unplug this product from the wall outlet before cleaning. Do not use liquid or aerosol cleaners. Use a damp cloth for cleaning.
4. Do not use this product near water.
5. Do not place this product on an unstable cart, stand or table. The product may fall, causing serious damage to the product.
6. Slots and openings on the cabinet and the back or bottom are provided for ventilation. To ensure reliable operation of the product and to protect it from overheating, do not block or cover these openings. The openings should never be blocked by placing the product on a bed, sofa, rug or other similar surface. This product should never be placed near or over a radiator or heat register. This product should not be placed in a built-in installation unless proper ventilation is provided.
7. This product should be operated from the type of power source indicated on the marking label. If you are not sure of the type of power available, consult your dealer or local power company.
8. This product is equipped with a 3-wire grounding-type plug, a plug having a third (grounding) pin. This plug will only fit into a grounding-type power outlet. This is a safety feature. If you are unable to insert the plug into the outlet, contact your electrician to replace your obsolete outlet. Do not defeat the safety purpose of the grounding-type plug.
9. Do not allow anything to rest on the power cord. Do not locate this product where the cord will be walked on.
10. If an extension cord is used with this product, make sure that the total of the ampere ratings on the products plugged into the extension cord do not exceed the extension cord ampere rating. Also, make sure that the total of all products plugged into the wall outlet does not exceed 15 amperes.
11. Never push objects of any kind into this product through cabinet slots as they may touch dangerous voltage points or short out parts that could result in a risk of fire or electric shock. Never spill liquid of any kind on the product.

12. Except as explained elsewhere in this manual, don't attempt to service this product yourself. Opening and removing those covers that are marked "Do Not Remove" may expose you to dangerous voltage points or other risks. Refer all servicing on those compartments to service personnel.
13. Unplug this product from the wall outlet and refer servicing to qualified service personnel under the following conditions:
 - A. When the power cord or plug is damaged or frayed.
 - B. If liquid has been spilled into the product.
 - C. If the product has been exposed to rain or water.
 - D. If the product does not operate normally when the operating instructions are followed. Adjust only those controls that are covered by the operating instructions since improper adjustment of other controls may result in damage and will often require extensive work by a qualified technician to restore the product to normal operation.
 - E. If the product has been dropped or the cabinet has been damaged.
 - F. If the product exhibits a distinct change in performance, indicating a need for service.

Chapter 1

INTRODUCTION

The ATX BX100 mainboard is a high-performance personal computer mainboard based on the Intel® Socket 370 processor. The Intel® Socket 370 processor supports MMX™ (Multimedia Extension) technology.

The mainboard uses the highly integrated Intel® 82443BX AGP chipset to support the PCI/ISA and Green standards, and to provide the Host/AGP bridge. The Intel® 82371EB chipset integrates all system control functions such as ACPI (Advanced Configuration and Power Interface). The ACPI provides more Energy Saving Features for the OSPM (OS Direct Power Management) function. The Intel® 82371EB chipset also improves the IDE transfer rate by supporting Ultra DMA/33 IDE that transfers data at the rate of 33MB/s.

The mainboard also supports the System Hardware Monitor Controller. Its functions include: CPU /power supply/chassis fan revolution detect, CPU/system voltage monitor, system temperature monitor, chassis intrusion detect and TOP TECH. III as an optional function.

Mainboard Features

CPU

- Socket 370 for Intel® Celeron™ & Pentium III Coppermine processor
- Supports 300MHz, 333MHz, 366MHz, 400MHz, 433MHz, 466MHz, 500MHz, 533MHz, 556MHz, 600MHz, 667MHz, 700MHz, 800MHz, 933MHz, 1GHz.

Chipset

- Intel® 82443BX/PIIX4E chipset.

FSB (Front Side Bus)

- 66.6MHz and 100MHz are supported.

Main Memory

- Supports six memory banks using three 168-pin unbuffered DIMM.
- Supports a maximum memory size of 768MB registered DIMM only.
- Supports 3.3v SDRAM DIMM.

Slots

- One AGP slot.
 - AGP specification compliant
 - AGP 66/133MHz 3.3v device support
- Five 32-bit Master PCI Bus slots and two 16-bit ISA Bus slots (wherein one PCI/ISA slot is shared).
*See page 2-32 for further details on PCI slots.
- Supports 3.3v/5v PCI bus Interface.

On-Board IDE

- An IDE controller on the Intel® PIIX4E PCI Chipset provides IDE HDD/CD-ROM with PIO, Bus Master and Ultra DMA/33 operation modes.
- Can connect up to four IDE devices.

On-Board Peripherals

- On-Board Peripherals include:
 - 1 floppy port supports 2 FDD with 360K, 720K, 1.2M, 1.44M and 2.88Mbytes.
 - 2 serial port (COM A) + (COM B)
 - 1 parallel port supports SPP/EPP/ECP mode
 - 2 USB ports
 - 1 IrDA connector for SIR.

BIOS

- The mainboard BIOS provides “Plug & Play” BIOS which detects the peripheral devices and expansion cards of the board automatically.
- The mainboard provides a Desktop Management Interface(DMI) function which records your mainboard specifications.
- ACPI(Advanced Configuration and Power Interface) feature.
- Anti-BIOS Virus function.

Dimension

- ATX Form Factor : 30.5cm(L) x 20.5cm(W) x 4 layers PCB

Mounting

- 6 mounting holes.

Other Features

- Keyboard Password Wake-Up
- LAN Wake-Up
- Internal/External Modem Wake-Up

System Hardware Monitor

- CPU/Power Supply/Chassis Fan Revolution Detect
- CPU Fan Control detects the CPU temperature, then determine the FAN SPEED, which utilizes PC Alert program (the fan will automatically stop when the system enters suspend mode)
- System Voltage Detect
- 5VSB and Battery Voltage Detect
- CPU Overheat Warning.
- Display Actual Current Voltage
- Chassis Intrusion

Mainboard Layout

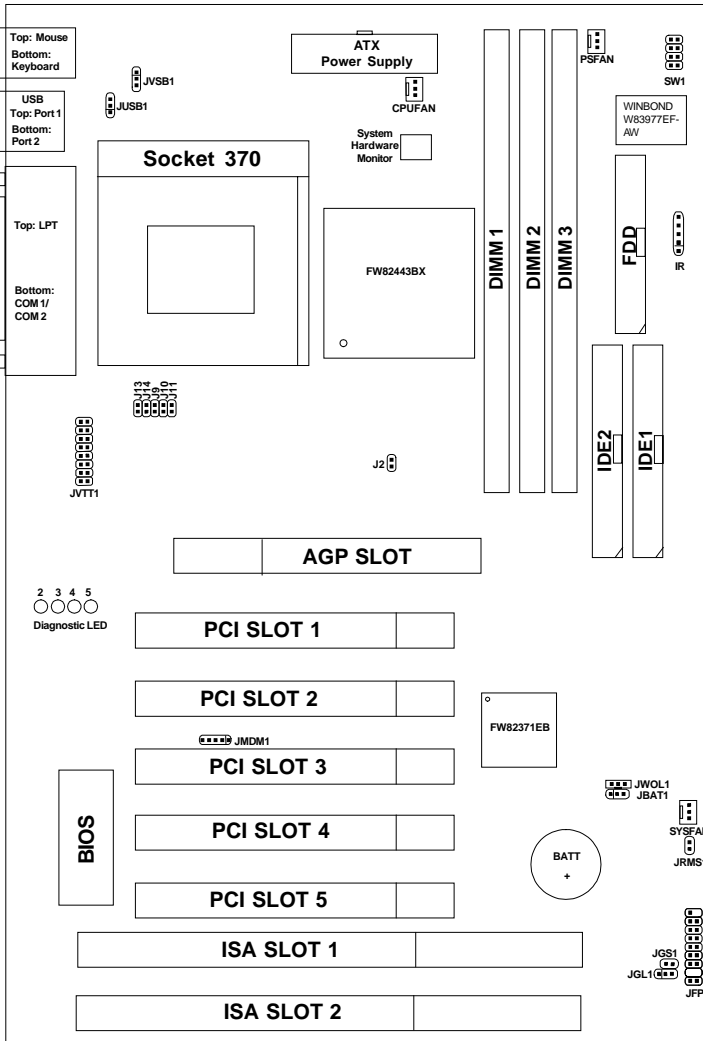

MS-6153 ATX Mainboard

Chapter 2

HARDWARE INSTALLATION

Central Processing Unit: CPU

The mainboard operates with **Intel® Celeron™ & Pentium® III processor**. The mainboard uses a CPU socket called Socket 370 for easy CPU installation. The CPU should always have a Heat Sink and a cooling fan attached to prevent overheating.

• CPU Installation Procedures

1. Pull the lever sideways away from the socket. Then, raise the lever up to a 90-degree angle.
2. Locate Pin 1 in the socket and look for the white dot or cut edge in the CPU. Match Pin 1 with the white dot/cut edge. Then, insert the CPU. It should insert easily.
3. Press the lever down to complete the installation.

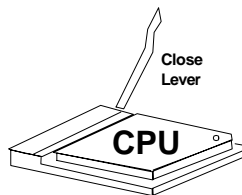
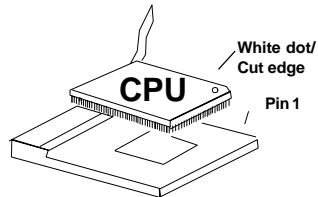
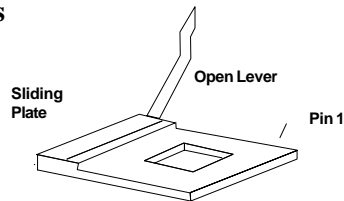

• **CPU Core Speed Derivation Procedure (SW1)**

If the CPU Core/Bus ratio is already fixed, adjusting the SW1 will not change the CPU Core/Bus ratio. If the Core/Bus ratio is not fixed by the CPU, then you can adjust the SW1 to change the Core/Bus ratio.

If	<u>CPU Clock</u>	=	66MHz
	<u>Core/Bus ratio</u>	=	3.5
then	<u>CPU core speed</u>	=	<u>Host Clock</u> x <u>Core/Bus ratio</u>
		=	66MHz x 3.5
		=	233MHz

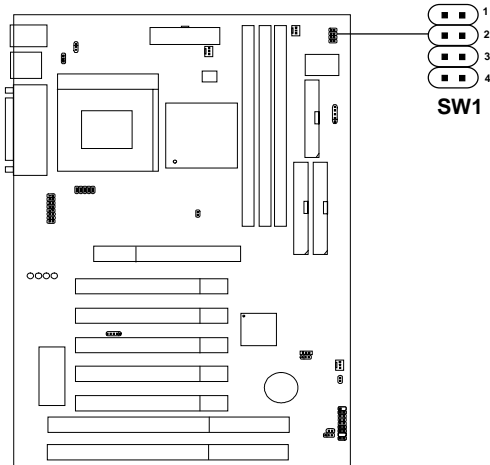



SW1				CPU
1	2	3	4	Core/Bus Ratio
ON	ON	OFF	ON	3
ON	OFF	OFF	ON	3.5
ON	ON	ON	OFF	4
ON	OFF	ON	OFF	4.5
ON	ON	OFF	OFF	5
ON	OFF	OFF	OFF	5.5
OFF	ON	ON	ON	6
OFF	OFF	ON	ON	6.5
OFF	ON	OFF	ON	7
OFF	OFF	OFF	ON	7.5
OFF	ON	ON	OFF	8

ON = Short**OFF = Open**

• **CPU Bus Frequency Selector: J9**

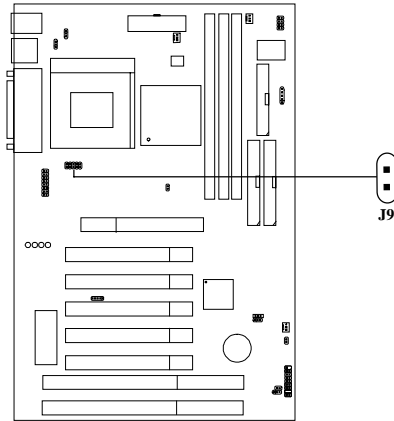
The J9 is used to set the CPU Bus Frequencies from 66MHz to 100MHz. When J9 is shorted, this will automatically detect the CPU Bus Frequency. When J9 is open, if you used 66MHz CPU, the Bus Frequency will be set virtually into 100MHz.





J9	Feature
	<p>Automatically detect 66MHz and 100MHz CPU Bus Frequency</p>
	<p>Virtually set 66MHz CPU Bus Frequency into 100MHz</p>

NOTE: 1. This feature works with 66MHz FSB only.
 2. If your CPU FSB supports 66MHz and you want to run it on 100MHz FSB, the J9 should be open. The AGP Bus will be set to run at 100MHz x 2/3=66MHz to make it stable.

• CPU Bus Frequency Selector 2: J10

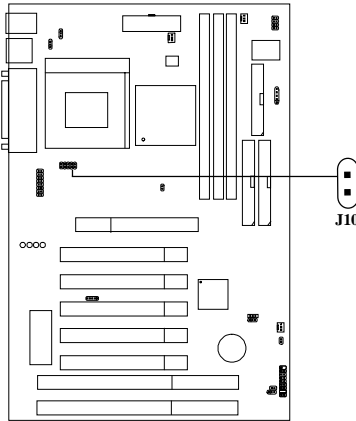
The J10 is used to set the CPU Bus Frequency from 100MHz to 133MHz. When J10 is shorted, this will automatically detect the CPU Bus Frequency. When J10 is open, if you used 100MHz CPU, the Bus Frequency will be set virtually into 133MHz.



J10	Feature
	<p>Automatically detect 133MHz or others CPU Bus Frequency</p>
	<p>Virtually set CPU Bus Frequency into 133MHz</p>

NOTE: 1. This feature works with 100MHz FSB only.
 2. If your CPU FSB supports 100MHz and you want to run it on 133MHz FSB, J10 should be open. The AGP Bus will be set to run at 133MHz x 1/2=66MHz to make it stable.

- **Intel® processor: J11, J13 & J14**

For **Intel®** processor, you need to open J11.
Please refer to the following table below.

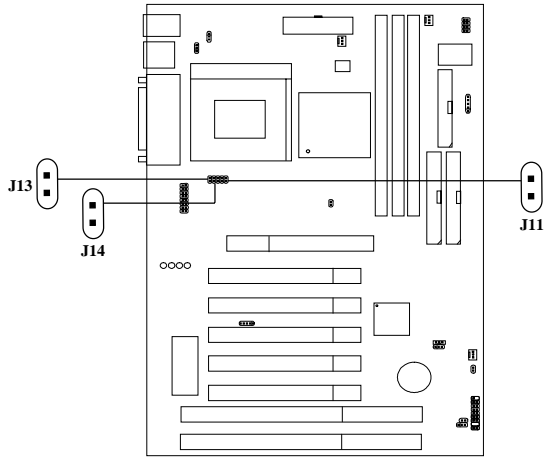

Jumper	Intel® Processor
J10	Short
J11	Open
J13	Open
J14	Open

• Fan Power Connectors: CPUFAN/PSEFAN/SYSFAN

These connectors support system cooling fan with +12V. It supports three pin head connector. When connecting the wire to the connector, always take note that the red wire is the positive and should be connected to the +12V, the black wire is Ground and should be connected to GND. If your mainboard has System Hardware Monitor chipset on-board, you must use a specially designed fan with speed sensor to take advantage of this function.

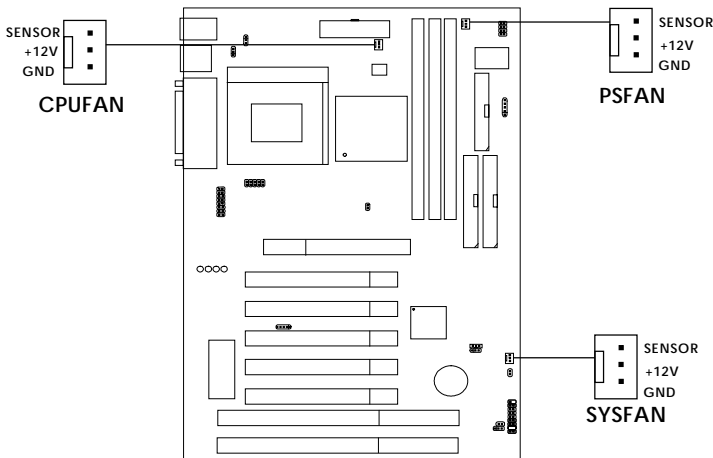

PSFAN : Power Supply Fan
CPUFAN : Processor Fan
SYSFAN : System(Chassis) Fan

For fans with fan speed sensor, every rotation of the fan will send out 2 pulses. System Hardware Monitor will count and report the fan rotation speed.

- Note:**
1. Always consult vendor for proper CPU cooling fan.
 2. CPU FAN supports the FAN control, you can install PC Alert utility. This will automatically set the CPU FAN Speed depending on the actual CPU temperature.

Clear CMOS Jumper: JBAT1

A battery must be used to retain the mainboard configuration in CMOS RAM. Short 1-2 pins of JBAT1 to store the CMOS data.

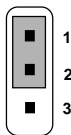
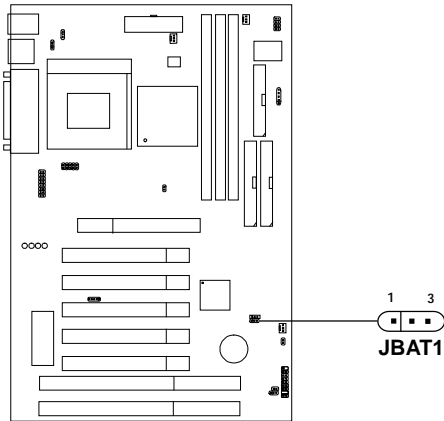

Keep Data

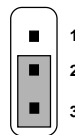

Clear Data

Note: You can clear CMOS by shorting 2-3 pin, while the system is off. Then, return to 1-2 pin position. Avoid clearing the CMOS while the system is on, it will damage the mainboard. Always unplug the power cord from the wall socket.

Memory Installation

• Memory Bank Configuration

The mainboard supports a maximum memory size of 768MB registered DIMM for SDRAM: It provides three 168-pin **unbuffered** DIMMs (Double In-Line Memory Module) sockets. It supports 8 MB to 256 Mbytes DIMM memory module.

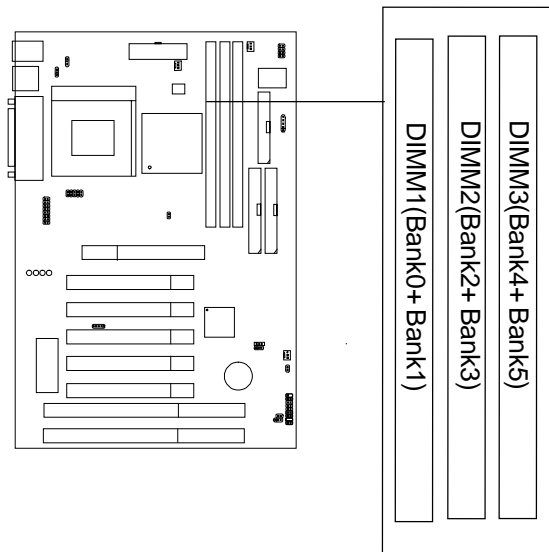

WARNING!

There are three kinds of DIMM specification supported by this mainboard: PC133, PC100 and PC66. If you use 66MHz CPU Bus Frequency, these three DIMM Specs. is supported. If you use 100MHz CPU Bus Frequency, PC100 & PC133 DIMM Specs. is supported. If you use 133MHz CPU Bus, only PC133 DIMM Specs. is supported.

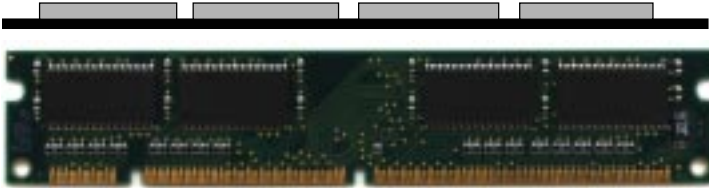
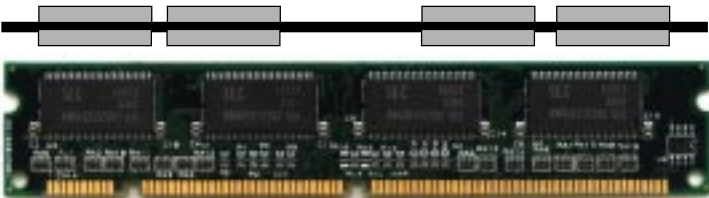
• Memory Installation Procedures**A. How to install a DIMM Module****Single Sided Bank DIMM****Double Sided Bank DIMM**

1. The DIMM slot has 2 Notch Keys “VOLT and DRAM”, so the DIMM memory module can only fit in one direction.
2. Insert the DIMM memory module vertically into the DIMM slot. Then push it in.

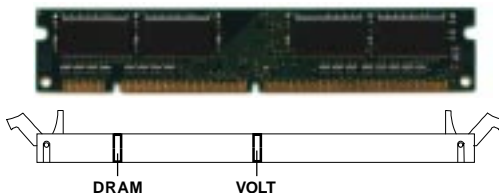

3. The plastic clip at the side of the DIMM slot will automatically close.

• **SDRAM Memory Addressing**

DRAM Tech.	DRAM Density & Width	DRAM Addressing	Address Size		MB/DIMM	
			Row	Column	Single no. Side(S) pcs.	Double no. Side(D) pcs.
16M	1Mx16	ASYM	11	8	8MBx4	16MBx8
	2Mx8	ASYM	11	9	16MBx8	32MBx16
	4Mx4	ASYM	11	10	32MB	64MB
64M	2Mx32	ASYM	11	9	32MBx2	64MBx4
	2Mx32	ASYM	12	8	16MBx2	32MBx4
	4Mx16	ASYM	11	10	32MB	64MB
	4Mx16	ASYM	13	8	32MB	64MB
	8Mx8	ASYM	13	9	64MB	128MB
	16Mx4	ASYM	13	10	128MB	256MB
	2Mx32	ASYM	12	8	16MB	32MB
64M	4Mx16	ASYM	13	8	32MB	64MB
	8Mx8	ASYM	13	9	64MB	128MB
	16Mx4	ASYM	13	10	128MB	256MB
	16Mx4	ASYM	13	10	128MB	256MB

Case Connector: JFP

The Power Switch, Reset Switch, Power LED, Speaker, Keylock and HDD LED are all connected to the JFP connector block.

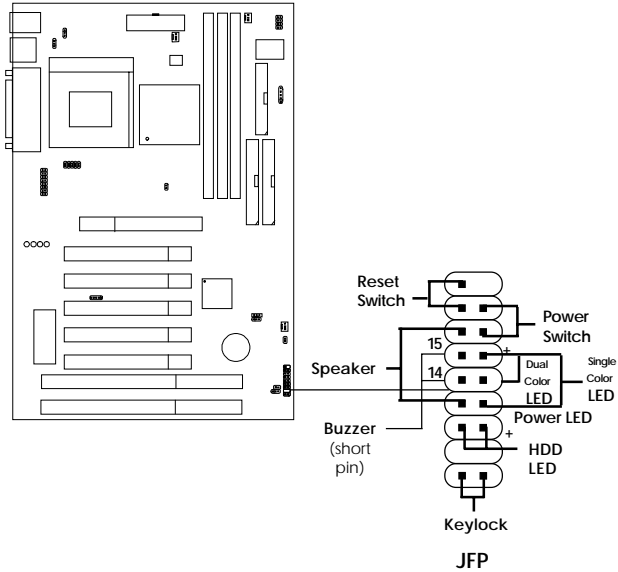

Power Switch

Connect to a 2-pin push button switch. This switch has the same feature with JRMS1.

Reset Switch

Reset switch is used to reboot the system rather than turning the power ON/OFF. Avoid rebooting while the HDD LED is lit. You can connect the Reset switch from the system case to this pin.

Power LED

The Power LED is lit while the system power is on. Connect the Power LED from the system case to this pin. There are two types of LED that you can use: 3-pin single color LED or 2-pin dual color LED (ACPI request).

- a. 3 pin single color LED connect to pin 4, 5, & 6. This LED will light when the system is on.
- b. 2 pin dual color LED connect to pin 5 & 6.

GREEN Color: Indicate the system is in full on mode.

ORANGE Color: Indicate the system is in suspend mode.

Speaker

Speaker from the system case is connected to this pin.

If on-board Buzzer is available:

Short pin 14-15: On-board Buzzer Enabled.

Open pin 14-15: On-board Buzzer Disabled.

HDD LED

HDD LED shows the activity of a hard disk drive. Avoid turning the power off while the HDD led is lit. You can connect the HDD LED from the system case to this pin.

Keylock

Keylock allows you to disable the keyboard for security purposes. You can connect the keylock to this pin.

Floppy Disk Connector: FDD

The mainboard also provides a standard floppy disk connector (FDD) that supports 360K, 720K, 1.2M, 1.44M and 2.88M floppy disk types. This connector supports the provided floppy drive ribbon cables.

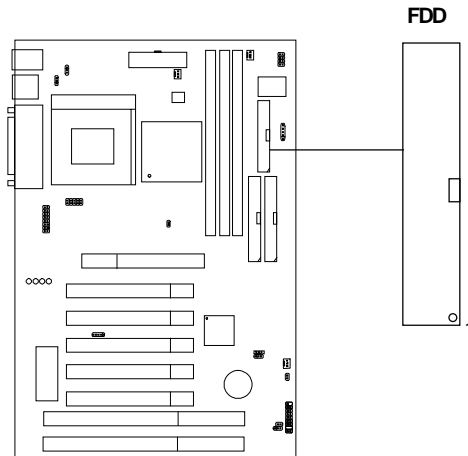

Hard Disk Connectors: IDE1 & IDE2

The mainboard has a 32-bit Enhanced PCI IDE Controller that provides PIO mode 0~4, Bus Master, and Ultra DMA 33 function. It has two HDD connectors IDE1 (primary) and IDE2 (secondary). You can connect up to four hard disk drives, CD-ROM, 120MB Floppy (reserved for future BIOS) and other devices to IDE1 and IDE2. These connectors support the provided IDE hard disk cable.

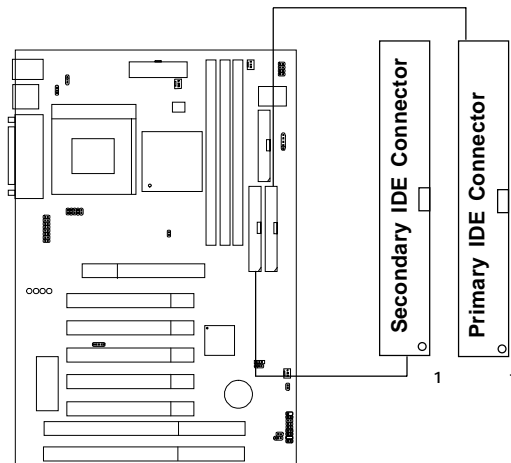

IDE1(Primary IDE Connector)

The first hard drive should always be connected to IDE1. IDE1 can connect a Master and a Slave drive. You must configure second hard drive to Slave mode by setting the jumper accordingly.

IDE2(Secondary IDE Connector)

IDE2 can also connect a Master and a Slave drive.

Power Supply

- **ATX 20-pin Power Connector: JWR1**

This connector supports the power button on-board. Using the ATX power supply, functions such as Modem Ring Wake-Up and Soft Power Off are supported by this mainboard. This power connector supports instant power on function which means that system will boot up instantly when the power connector is inserted on the board.

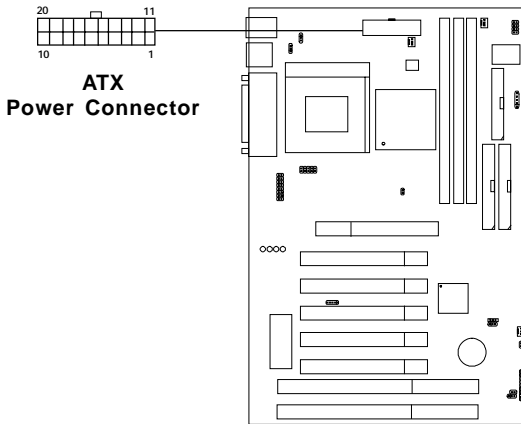

PIN DEFINITION

PIN	SIGNAL	PIN	SIGNAL
1	3.3V	11	3.3V
2	3.3V	12	-12V
3	GND	13	GND
4	5V	14	PS_ON
5	GND	15	GND
6	5V	16	GND
7	GND	17	GND
8	PW_OK	18	-5V
9	5V_SB	19	5V
10	12V	20	5V

Warning: Since the mainboard has the instant power on function, make sure that all components are installed properly before inserting the power connector to ensure that no damage will be done.

- **Remote Power On/Off Switch: JRMS1**

Connect to a 2-pin push button switch. During OFF state, press once and the system turns on. **During ON stage, push once and the system goes to sleep mode: pushing it more than 4 seconds will change its status from ON to OFF.** If you want to change the setup, you could go to the BIOS Power Management Setup.

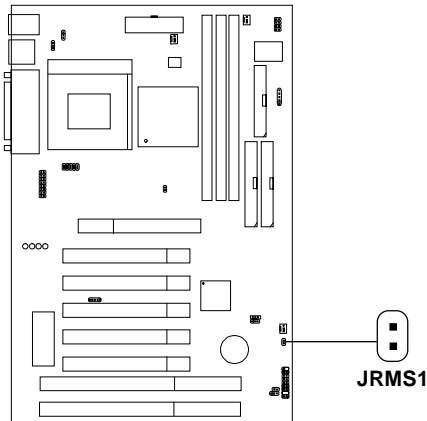

IrDA Infrared Module Connector: IR

The mainboard provides one 5-pin infrared (IR) connector for IR modules. This connector is for optional wireless transmitting and receiving infrared module. You must configure the setting through the BIOS setup to use the IR function.

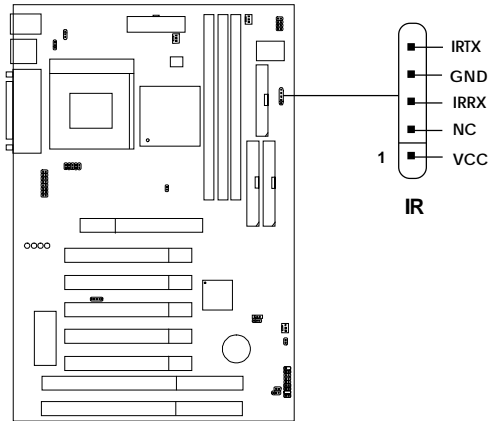

Serial Port Connectors: COM A and COM B

The mainboard has two 9-pin male DIN connectors for serial port COM A and COM B. These ports are 16550A high speed communication port that send/receive 16 bytes FIFOs. You can attach a mouse or a modem cable directly into this connector.

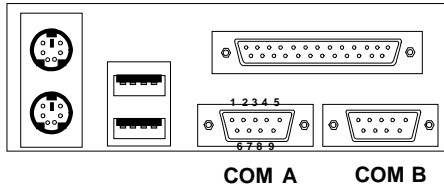

Serial Port (9-pin Male)

PIN DEFINITION

PIN	SIGNAL
1	DCD (Data Carry Detect)
2	SIN (Serial In or Receive Data)
3	SOUT (Serial Out or Transmit Data)
4	DTR (Data Terminal Ready)
5	GND
6	DSR (Data Set Ready)
7	RTS (Request To Send)
8	CTS (Clear To Send)
9	RI (Ring Indicate)

Parallel Port Connector: LPT1

The mainboard provides a 25 pin female centronic connector for LPT. A parallel port is a standard printer port that also supports Enhanced Parallel Port (EPP) and Extended capabilities Parallel Port (ECP). See connector and pin definition below:

Parallel Port (25-pin Female)

LPT 1

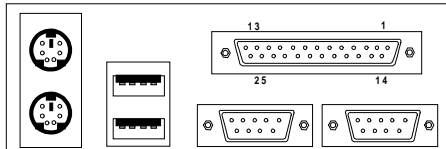

PIN DEFINITION

PIN	SIGNAL	PIN	SIGNAL
1	STROBE	14	AUTO FEED#
2	DATA0	15	ERR#
3	DATA1	16	INIT#
4	DATA2	17	SLIN#
5	DATA3	18	GND
6	DATA4	19	GND
7	DATA5	20	GND
8	DATA6	21	GND
9	DATA7	22	GND
10	ACK#	23	GND
11	BUSY	24	GND
12	PE	25	GND
13	SELECT		

Mouse Connector: JKBMS1

The mainboard provides a standard PS/2® mouse mini DIN connector for attaching a PS/2® mouse. You can plug a PS/2® mouse directly into this connector. The connector location and pin definition are shown below:

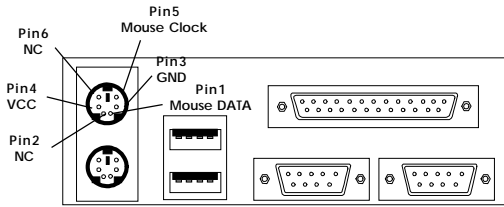

PS/2 Mouse (6-pin Female)

Keyboard Connector: JKBMS1

The mainboard provides a standard PS/2® keyboard mini DIN connector for attaching a keyboard. You can plug a keyboard cable directly to this connector.

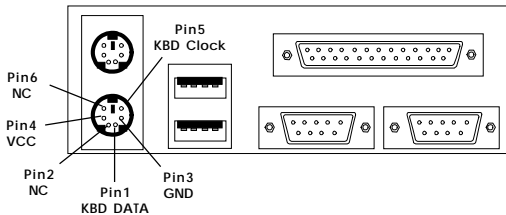

PS/2 Keyboard (6-pin Female)

USB Connectors

The mainboard provides a **UHCI (Universal Host Controller Interface) Universal Serial Bus root** for attaching USB devices like: keyboard, mouse and other USB devices. You can plug the USB device directly to this connector.

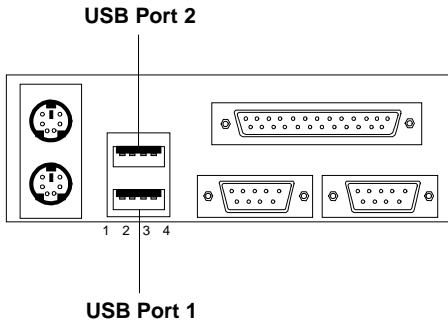

PIN	SIGNAL
1	VCC
2	-Data0
3	GND
4	+Data0

Power Saving Switch Connector: JGS1

Attach a power saving switch to **JGS1**. When the switch is pressed, the system immediately goes into suspend mode. Press any key and the system wakes up.

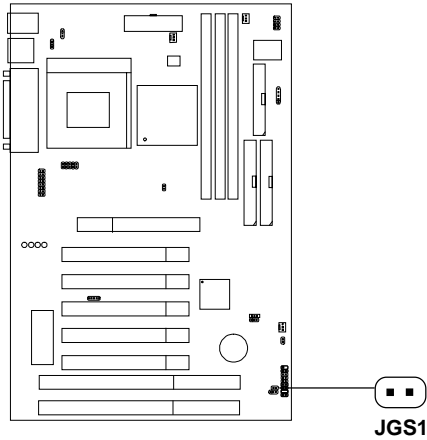

Power Saving LED Connector: JGL1

JGL1 can be connected with an LED. There are two types of LED that you can use: 3-pin LED or 2-pin LED (ACPI request). When the 2-pin LED is connected to JGL1, the light will turn green, when system is On. During sleep mode, the 2-pin LED will change color from Green to Orange. For 3-pin LED, when LED is connected to JGL1, this will light when the system is On and blinks when it is in suspend/sleep mode.

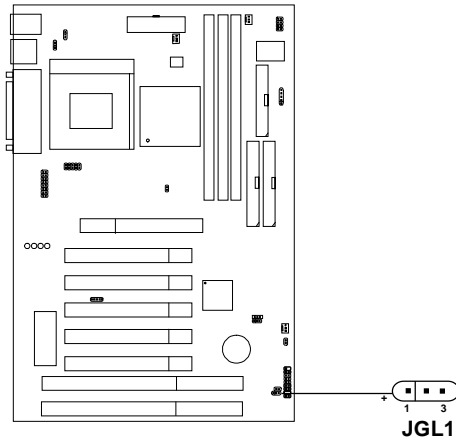

3-pin LED	2-pin LED
<p>Green Color</p> <p>Orange Color</p>	<p>Green Color</p> <p>Orange Color</p>
<p>2-3 Single Color 1-3 Blink</p>	<p>1-2 Dual Color</p>

Wake-Up on LAN Connector: JWOL1

The JWOL1 connector is for use with LAN add-on cards that supports Wake Up on LAN function. To use this function, you need to set the “Wake-Up on LAN” to enable at the BIOS Power Management Setup.

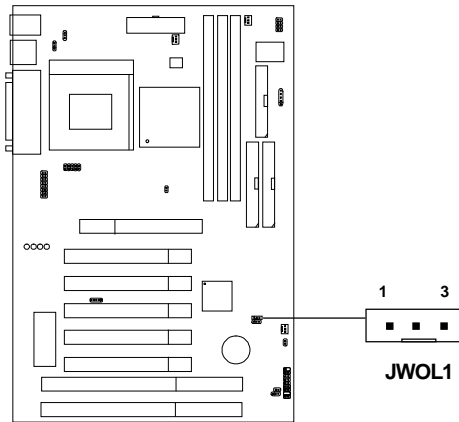

PIN	SIGNAL
1	5VSB
2	GND
3	MP_WAKEUP

Note: LAN wake-up signal is active “high”.

Note: To be able to use this function, you need a power supply that provide enough power for this feature.
(Power supply with 750 mA 5V Stand-by)

Modem Wake Up Connector: JMDM1

The JMDM1 connector is use for the Modem add-on card which supports the Modem Wake Up function. To use this function, you need to set the “Modem Ring Resume” to enable at the BIOS Power Management Setup.

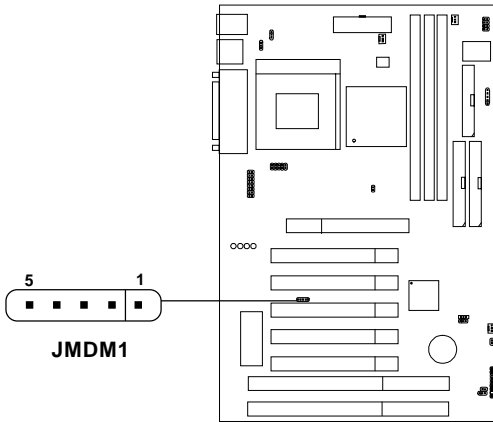

PIN	SIGNAL
1	NC
2	GND
3	MDM_WAKEUP
4	NC
5	5VSB

Note: Modem wake-up signal is active “low”.

Note: To be able to use this function, you need a power supply that provide enough power for this feature.
(Power supply with 750 mA 5V Stand-by)

TOP TECH. III: J2 (optional)

This is used to check the AGP card or BX chipset temperature. The J2 is a 2-pin connector which can be inserted with a 20cm length thermistor. It is located near the chipset heatsink that monitors the chipset temperature. The BIOS setup for “TOP TECH. III” should be set to enabled if you want to detect the chipset temperature.

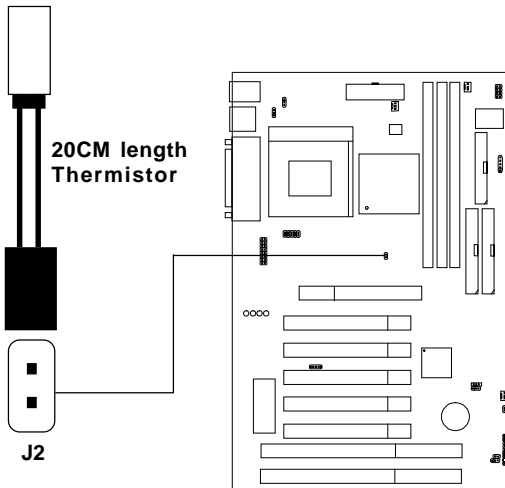

Keyboard Power: JVSBI

The JVSBI jumper is for setting keyboard power. This function should be set in the BIOS for the keyboard and PS/2 mouse Wake-up function.

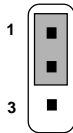
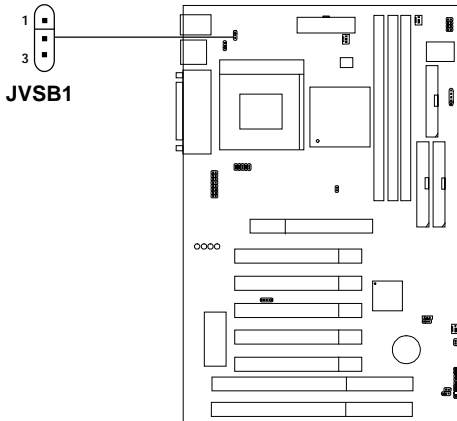

5V Standby (default)
Enable keyboard
power on function

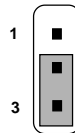

5V
Disable keyboard
power on function

Note: To be able to use this function, you need a power supply that provide enough power for this feature.
(Power supply with 750 mA 5V Stand-by)

USB Device Power Jumper: JUSB1

This jumper provides Vcc or 5V standby setting for USB Device Power.

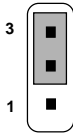
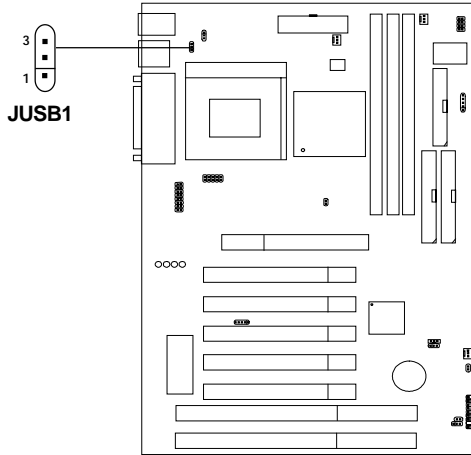

**5V Standby
Enabled**

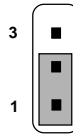

**5V (default)
Disabled**

CPU Termination Voltage Jumper:
JVTT1 (reserved)

The JVTT1 is a reserved function for future Coppermine CPU.

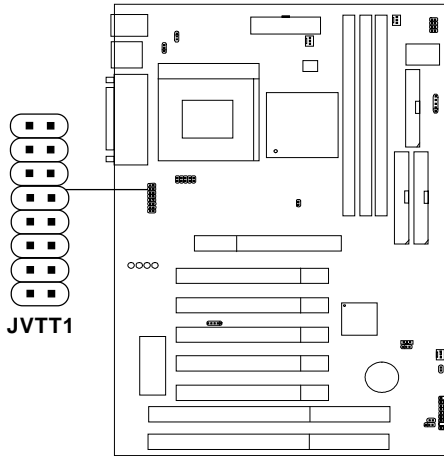

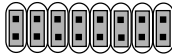
JVTT1	Function
	<p>For Celeron</p>
	<p>For Coppermine</p>

PCI and ISA Slots

There are 5 PCI slots and 2 ISA slots. All PCI slots can be used as master. The 1st and 5th PCI slots share the same bus master signal, only one of these slots can be used as a master at a time; which means that if a master card is installed in PCI slot 1, PCI Slot 5 can only accomodate a slave card, and vice versa.

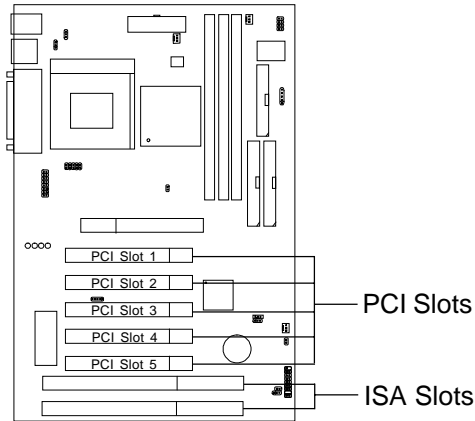

Diagnostic LED

The mainboard provides a Special Diagnostic LED for users to be aware of their mainboard conditions. The LED helps user determine the problem of the mainboard.

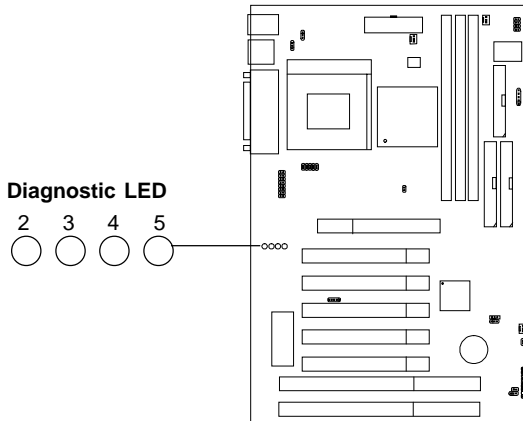

Diagnostic LED Function

Diagnostic LED 2 3 4 5	Description	Possible Problem/ Solution
0 0 0 0	System Power ON. This will start BIOS Initialization	The Processor might be damage or not installed properly Damage/Discharge Lithium Battery
0 0 0 1	Early Chipset Initialization	***
0 0 1 0	Memory Detection Test Testing Onboard memory size	The Memory module might be damage or not installed properly.
0 0 1 1	Decompressing BIOS image to RAM for fast booting.	***
0 1 0 0	Initializing Keyboard Controller	*If there is no keyboard connected, D-LED will blink 3 times.
0 1 0 1	Test shadow RAM (R/W Shadow RAM Area)	***
0 1 1 0	Processor Initialization This will show information regarding the processor (like brand name, system bus, etc...)	***
0 1 1 1	Testing RTC (Real Time Clock)	Low Lithium Battery *If RTC battery is low or failed, D-LED will blink 3 times.
1 0 0 0	Initializing Video Interface This will start detecting CPU clock, checking type of video onboard. Then, detect and initialize the video adapter	System D-LED will produce Beep sound The VGA card might be damage or not inserted properly. *If there is no VGA installed, D-LED will blink 3 times.
1 0 0 1	BIOS Sign On This will start showing information about Logo, processor brand name, etc.....	***
1 0 1 0	Testing Base and Extended Memory Testing base memory from 240K to 640K and extended memory above 1MB using various patterns.	***
1 0 1 1	Assign Resource to all ISA	***
1 1 0 0	Initializing Hard Drive Controller This will initialize IDE drive and controller	Check IDE cable for proper installation *If there is no HDD connected, D-LED will blink 3 times.
1 1 0 1	Initializing Floppy Drive Controller This will initialize Floppy Drive and controller	The Floppy Drive Cable might not be installed properly
1 1 1 0	Assign IRQs to PCI Devices	***
1 1 1 1	Operating System Booting.	***

1 = GREEN 0 = RED

***** Check local Vendor for possible internal mainboard problem.**

Chapter 3

AWARD® BIOS SETUP

Award® BIOS ROM has a built-in Setup program that allows users to modify the basic system configuration. This type of information is stored in battery-backed RAM (CMOS RAM), so that it retains the Setup information when the power is turned off.

Entering Setup

Power on the computer and press immediately to allow you to enter Setup. The other way to enter Setup is to power on the computer. When the below message appears briefly at the bottom of the screen during the POST (Power On Self Test), press key or simultaneously press <Ctrl>, <Alt>, and <Esc> keys.

TO ENTER SETUP BEFORE BOOT PRESS <CTRL-ALT-ESC>
OR KEY

If the message disappears before you respond and you still wish to enter Setup, restart the system to try again by turning it OFF then ON or pressing the “RESET” button on the system case. You may also restart by simultaneously pressing <Ctrl>, <Alt>, and <Delete> keys. If you do not press the keys at the correct time and the system does not boot, an error message will be displayed and you will again be asked to,

PRESS <F1> TO CONTINUE, <CTRL-ALT-ESC>
OR TO ENTER SETUP

Getting Help

Main Menu

The on-line description of the highlighted setup function is displayed at the bottom of the screen.

Status Page Setup Menu/Option Page Setup Menu

Press F1 to pop up a small help window that describes the appropriate keys to use and the possible selections for the highlighted item. To exit the Help Window press <F1> or <Esc>.

Chipset Features Setup

This setup page includes all the items of chipset special features.

Power Management Setup

This category determines the power consumption for system after setting the specified items. Default value is Disable.

PNP/PCI Configuration Setup

This category specifies the IRQ level for PCI and ISA devices.

Load Setup Defaults

Chipset defaults indicates the values required by the system for the maximum performance.

CPU Plug & Play III

This function supports CPU Plug & Play III and Special Hardware Monitor.

Integrated Peripherals

Change, set or disable onboard I/O, IRQ, and DMA assignment.

Supervisor Password/User Password

Change, set or disable password. This function allows the user access to the system and setup or just setup.

IDE HDD Auto Detection

Automatically configure hard disk parameters.

Save & Exit Setup

Save CMOS value changes to CMOS and exit setup.

Exit Without Saving

Abandon all CMOS value changes and exit setup.

Standard CMOS Setup

The items in Standard CMOS Setup Menu are divided into 10 categories. Each category includes no, one or more than one setup items. Use the arrow keys to highlight the item and then use the <PgUp> or <PgDn> keys to select the value you want in each item.

ROM PCI/ISA BIOS (2A59IM4A)
STANDARD CMOS SETUP
AWARD SOFTWARE, INC.

Date(mm:dd:yy): Fri, Jan 29,1999							
Time(hh:mm:ss): 00:00:00							
HARD DISKS	TYPE	SIZE	CYLS	HEADS	PRECOMP	LANDZONE	SECTOR MODE
Primary Master:	Auto	0	0	0	0	0	AUTO
Primary Slave :	Auto	0	0	0	0	0	AUTO
Secondary Master :	Auto	0	0	0	0	0	AUTO
Secondary Slave :	Auto	0	0	0	0	0	AUTO
Drive A :	1.44M,3.5in.			Base Memory:		640K	
Drive B :	None			Extended Base Memory:		15360K	
Video :	EGA/VGA			Other Memory:		384K	
Halt On :	All, but Keyboard			Total Memory:		16384K	
ESC : Quit ↑↓→← : Select Item PU/PD/+/- : Modify F1 : Help (Shift)F2 : Change Color							

Date

The date format is <day><month> <date> <year>.

Day	Day of the week, from Sun to Sat, determined by BIOS. Read-only.
month	The month from Jan. through Dec.
date	The date from 1 to 31 can be keyed by numeric function keys.
year	The year, depends on the year of the BIOS

Time

The time format is <hour> <minute> <second>.

**PrimaryMaster/PrimarySlave
SecondaryMaster/Secondary Slave**

These categories identify the types of 2 channels that have been installed in the computer. There are 45 pre-defined types and 4 user definable types for Enhanced IDE BIOS. Type 1 to Type 45 are pre-defined. Type User is user-definable.

Press PgUp/<+> or PgDn/<-> to select a numbered hard disk type or type the number and press <Enter>. Note that the specifications of your drive must match with the drive table. The hard disk will not work properly if you enter improper information for this category. If your hard disk drive type is not matched or listed, you can use Type User to define your own drive type manually.

If you select Type User, related information is asked to be entered to the following items. Enter the information directly from the keyboard and press <Enter>. This information should be provided in the documentation from your hard disk vendor or the system manufacturer.

If the controller of HDD interface is ESDI, the selection shall be
“Type 1”.

If the controller of HDD interface is SCSI, the selection shall be
“None”.

If the controller of HDD interface is CD-ROM, the selection shall be
“None”.

CYLS.	number of cylinders
HEADS	number of heads
PRECOMP	write precom
LANDZONE	landing zone
SECTORS	number of sectors
MODEHDD	access mode

BIOS Features Setup

ROM PCI/ISA BIOS (2A59IM4A)
BIOS FEATURES SETUP
AWARD SOFTWARE, INC.

Anti-Virus Protection	: Disabled	Video BIOS Shadow	: Enabled
CPU Internal Cache	: Enabled	C8000-CBFFF Shadow	: Disabled
External Cache	: Enabled	CC000-CFFFF Shadow	: Disabled
CPU L2 Cache ECC Checking:	Enabled	D0000-D3FFF Shadow	: Disabled
Processor Number Feature	: Enabled	D4000-D7FFF Shadow	: Disabled
Quick Power on Self Test	: Disabled	D8000-D8FFF Shadow	: Disabled
Boot From LAN First	: Disabled	DC000-DFFFF Shadow	: Disabled
Boot Sequence	: A,C,SCSI		
Swap Floppy Drive	: Disabled		
Boot Up Floppy Seek	: Enabled		
Floppy FIFO Control	: Disabled		
Boot up NumLock status	: On		
Gate A20 Option	: Fast		
Security Option	: Setup		
PCI/VGA palette snoop	: Disabled		
OS select for DRAM>64MB	: Non-OS2		
Report No FDD For WIN 95	: Yes		
		Esc : Quit	↑↓→← : Select item
		F1 : Help	PU/PD/+/- : modify
		F5 : Old Value(Shift)	F2 : Color
		F6 : Load BIOS Defaults	
		F7 : Load Setup Defaults	

Anti-Virus Protection

During and after the system boots up, any attempt to write to the boot sector or partition table of the hard disk drive will halt the system and the following error message will appear. For the meantime, you can run an anti-virus program to locate the problem.

Disable(default)

No warning message to appear when anything attempts to access the boot sector or hard disk partition table.

Enable

Activates automatically when the system boots up causing a warning message to appear when anything attempts to access the boot sector of hard disk partition table.

CPU Internal Cache

The default value is Enabled.

Enabled (default) Enable cache

Disabled Disable cache

Note: The internal cache is built in the processor.

External Cache

Choose Enabled or Disabled. This option enables the level 2 cache memory.

CPU L2 Cache ECC Checking

Choose Enabled or Disabled. This option enables the level 2 cache memory ECC (Error Check Correction). Using 66MHz CPU BUS processor, set to Enabled or Disabled. For Celeron™ processor w/o Cache, always set to Disabled.

Processor Number Feature

This option is for Pentium III processor. During Enabled, this will check the CPU Serial number. Disable this option, if you don't want the system to know the Serial number.

Quick Power On Self Test

This category speeds up Power On Self Test (POST) after you power on the computer. If this is set to Enabled, BIOS will shorten or skip some check items during POST.

Enabled Enable quick POST

Disabled (default) Normal POST

Boot From LAN First

During Enabled, if there's a LAN card onboard, the priority from booting will be from the LAN.

Boot Sequence

This category determines which drive the computer searches first for the disk operating system (i.e., DOS). The settings are A,C,SCSI/C,A,SCSI/C,CD-ROM,A/CD-ROM,C,A/D,A,SCSI/E,A,SCSI/F,A,SCSI/SCSI,A,C/SCSI,C,A/C,LS/ZIP,C only. Default value is A,C,SCSI.

Swap Floppy Drive

Switches the floppy disk drives between being designated as A and B. Default is Disabled.

Boot Up Floppy Seek

During POST, BIOS will determine if the floppy disk drive installed is 40 or 80 tracks. 360K type is 40 tracks while 760K, 1.2M and 1.44M are all 80 tracks.

Floppy FIFO Control

During Enabled, the FDD disk will perform better.

Boot Up NumLock Status

The default value is On.

On (default)	Keypad is numeric keys.
Off	Keypad is arrow keys.

Gate A20 Option

Normal	The A20 signal is controlled by keyboard controller or chipset hardware.
Fast (default)	The A20 signal is controlled by port 92 or chipset specific method.

Security Option

This category allows you to limit access to the system and Setup, or just to Setup.

- | | |
|------------------------|---|
| System | The system will not boot and access to Setup will be denied if the correct password is not entered at the prompt. |
| Setup (default) | The system will boot, but access to Setup will be denied if the correct password is not entered at the prompt. |

PCI VGA Palette Snooping

Choose Disabled or Enabled. Some graphic controllers which are not VGA compatible, take the output from a VGA controller and map it to their display as a way to provide the boot information and the VGA compatibility.

However, the color information coming from the VGA controller is drawn from the palette table inside the VGA controller to generate the proper colors, and the graphic controller needs to know what is in the palette of the VGA controller. To do this, the non-VGA graphic controller watches for the Write access to the VGA palette and registers the snoop data. In PCI based systems, where the VGA controller is on the PCI bus and a non-VGA graphic controller is on an ISA bus, the Write Access to the palette will not show up on the ISA bus if the PCI VGA controller responds to the Writes.

In this case, the PCI VGA controller should not respond to the Write. It should only snoop the data and permit the access to be forwarded to the ISA bus. The non-VGA ISA graphic controller can then snoop the data on the ISA bus. Unless you have the above situation, you should disable this option.

- | | |
|---------------------------|-----------------------|
| Disabled (default) | Disables the function |
| Enabled | Enables the function |

OS Selection for DRAM > 64MB

Allows OS2® to be used with > 64 MB of DRAM. Settings are Non-OS/2 (default) and OS2. Set to OS/2 if using more than 64MB and running OS/2®.

Report No FDD For WIN 95

This function is only used when you are testing SCT for Windows® 95 Logo.

Video BIOS Shadow

Determines whether video BIOS will be copied to RAM for faster execution. Video shadow will increase the video performance.

Enabled (default)

Video shadow is enabled

Disabled

Video shadow is disabled

C8000-CBFFF/DC000-DFFFF Shadow

Determine whether the optimal ROM will be compiled to RAM for faster execution.

Enabled

optional shadow is enabled

Disabled(default)

optional shadow is disabled

Chipset Features Setup

The Chipset Features Setup option is used to change the values of the chipset registers. These registers control most of the system options in the computer.

Choose the “CHIPSET FEATURES SETUP” from the Main Menu and the following screen will appear.

ROM PCI/ISA BIOS(2A59IM4A)
CMOS SETUP UTILITY
CHIPSET FEATURES SETUP

SDRAM Controlled by	:Manual	Auto Detect DIMM/PCI Clk	:Enabled
SDRAM RAS to CAS Delay	:3		
SDRAM RAS Precharge Time	:3		
SDRAM CAS Latency Time	:3		
DRAM Data Integrity Mode	:Non-ECC		
System BIOS Cacheable	:Disabled		
Video BIOS Cacheable	:Disabled		
Video RAM Cacheable	:Disabled		
8 Bit I/O Recovery Time	:1		
16 Bit I/O Recovery Time	:1		
Memory Hole at 15M-16M	:Disabled		
Passive Release	:Enabled		
Delayed Transaction	:Disabled		
AGP Aperture Size (MB)	:64		
		Esc : Quit ↑↓→← : Select item	
		F1 : Help PU/PD/+/- : modify	
		F5 : Old Value(Shift) F2 : Color	
		F6 : Load BIOS Defaults	
		F7 : Load Setup Defaults	

Note: Change these settings only if you are familiar with the chipset.

SDRAM Controlled by

Choose SPD, the SDRAM time will load from the DIMM EEPROM value. Choose manual, the value will be set by SDRAM Ras-to-CAS Delay and SDRAM CAS Latency Time. The settings are SPD and Manual.

If the DIMM is without EEPROM, then set this item to Manual. Set SDRAM Ras-to-CAS Delay and SDRAM CAS Latency Time to 3.

SDRAM RAS to CAS Delay

You can select the SDRAM RAS to CAS delay time in HCLKs of 2 or 3 (default). This should be set depending on the SDRAM installed.

SDRAM RAS Precharge Time

You can select the SDRAM RAS Precharge time in HCLKs of 2 or 3 (default). This should be set depending on the SDRAM installed.

SDRAM CAS Latency Time

You can select CAS latency time in HCLKs of 2 or 3 (default). This should be set depending on the SDRAM installed.

DRAM Data Integrity Mode

Select Non-ECC or ECC(error-correcting code), according to the type of installed DRAM. The settings are Non-ECC (default) or ECC.

System BIOS Cacheable

Select Enabled allows caching of the system BIOS ROM at F000h-FFFFFh, resulting in better system performance. However, if any program writes to this memory area, a system error may result.

Enabled	BIOS access cached
Disabled	BIOS access not cached

Video BIOS Cacheable

Select Enabled allows caching of the system BIOS ROM at C0000h-F7FFFh, resulting in better video performance. However, if any program writes to this memory area, a system error may result.

Enabled	Video BIOS access cached
Disabled	Video BIOS access not cached

Video RAM Cacheable

Select Enabled allows caching of the video RAM, resulting in better system performance. However, if any program writes to this memory area, a system error may result.

8 Bit I/O Recovery Time

The recovery time is the length of time, measured in CPU clocks, which the system will delay after the completion of an input/output request. This delay takes place because the CPU is operating so much faster than the input/output bus that the CPU must be delayed to allow for the completion of the I/O.

This item allows you to determine the recovery time allowed for 8 bit I/O. Choices are from NA, 1 to 8 CPU clocks.

16 Bit I/O Recovery Time

This item allows you to determine the recovery time allowed for 16 bit I/O. Choices are from NA, 1 to 4 CPU clocks.

Memory Hole At 15M-16M

In order to improve performance, certain space in memory can be reserved for ISA cards. This memory must be mapped into the memory space below 16 MB.

Enabled	Memory hole supported.
Disabled	Memory hole not supported.

Passive Release

When Enabled, CPU to PCI bus accesses are allowed during passive release. Otherwise, the arbiter only accepts another PCI master access to local DRAM. The settings are Enabled or Disabled.

Delayed Transaction

The chipset has an embedded 32-bit posted write buffer to support delay transactions cycles. Select Enabled to support compliance with PCI specification version 2.1. The settings are Enabled or Disabled.

AGP Aperture Size (MB)

Select the size of the Accelerated Graphics Port (AGP) aperture. The aperture is a portion of the PCI memory address range dedicated for graphics memory address space. Host cycles that hit the aperture range are forwarded to the AGP without any translation.

Auto Detect DIMM/PCI Clk

This item allows you to select the DIMM/PCI clock. The other sockets will not generate when DIMM/PCI cards are not installed. The setting should be set to enabled which works better for EMI.

Power Management Setup

The Power Management Setup will appear on your screen like this:

ROM PCI/ISA BIOS (2A59IM4A)
POWER MANAGEMENT SETUP
 AWARD SOFTWARE, INC.

ACPI Function	:Enabled	IRQ 8 Break Suspend	:Disabled
Power Management	:User Define		
PM Control by APM	:Yes	** Reload Global Timer Events **	
Video Off Method	:DPMS	IRQ [3-7,9-15],NMI	: Disabled
Video Off After	:Standby	Primary IDE 0	: Enabled
Modem Use IRQ	:3	Primary IDE 1	: Enabled
Doze Mode	:Disable	Secondary IDE 0	: Disabled
Standby Mode	:Disable	Secondary IDE 1	: Disabled
Suspend Mode	:Disable	Floppy Disk	: Disabled
HDD Power Down	:Disable	Serial Port	: Enabled
Throttle Duty Cycle	:62.5%	Parallel Port	: Disabled
PCI/VGA Act_Monitor	:Disabled		
Soft-Off by PWR-BTTN	:Instant-Off		
CPUFAN off in Suspend	:Enabled		
Power On by Ring	:Disabled		
Power status LED	:Dual Color		
Resume by Alarm	:Disabled		
Date(of Month) Alarm	:2	Esc : Quit	↑ ↓ → ← : Select item
Time(hh:mm:ss) Alarm	:0:0:0	F1 : Help	PU/PD/+/- : modify
		F5 : Old Value(Shift)	F2 : Color
		F6 : Load BIOS Defaults	
		F7 : Load Setup Defaults	
Wake Up on LAN	:Enabled		

ACPI Function

This item allows you to Enable or Disable the Advanced Configuration and Power Management.

Power Management

This category determines the power consumption for system after selecting below items. Default value is user define. The following pages tell you the options of each item & describe the meanings of each options.

Power Management

Disable	Global Power Management will be disabled.
User Define	Users can configure their own power management.
Min Saving	Pre-defined timer values are used such that all timers are in their MAX value.
Max Saving	Pre-defined timer values are used such that all timers are in their MIN value.

PM Control by APM

No	System BIOS will ignore APM when power managing the system.
Yes	System BIOS will wait for APM's prompt before it enter any PM mode

Note: Enable this for O.S. with APM like Windows® 95/98, Windows® NT, etc.

Video Off Method

Blank Screen	The system BIOS will only blank off the screen when disabling video.
V/H SYN C+Blank	In addition to (1), BIOS will also turn off the V-SYNC & H-SYNC signals from VGA card to monitor.
DPMS	This function is enabled only for VGA card supporting DPMS.

Note: Green monitors detect the V/H SYNC signals to turn off its electron gun.

Video Off After

The settings are N/A, Standby, Doze, or Suspend. This option is for choosing the setting in which the monitor will turn off.

- N/A** Always turn on.
 - Doze** During Doze mode, the monitor will be turned off.
 - Standby** During Standby mode, the monitor will be turned off.
 - Suspend** During Suspend mode, the monitor will be turned off.
- The default setting is Standby.

MODEM Use IRQ

Name the interrupt request (IRQ) line assigned to the modem (if any) on your system. Activity of the selected IRQ always awakens the system. The settings are NA, 3, 4, 5, 7, 9, 10, or 11.

Doze Mode

- Disable** System will never enter DOZE mode.
- 1 Min/2 Min/**
4 Min/8 Min/
12 Min/20 Min/
30 Min/40 Min/
1 Hr Defines the continuous idle time before the system enters DOZE mode. If any item defined in the options of “Power Down and Resume events” is enabled & active, DOZE timer will be reloaded. When the system have entered Doze mode, any of the items enabled in “Wake Up Events in Doze and Standby” will trigger the system to wake up.

Standby Mode**Disable**

System will never enter STANDBY mode.

1 Min/2 Min/

Defines the continuous idle time before the system enters STANDBY mode.

4 Min/8 Min/**12 Min/20 Min/****30 Min/40 Min/****1 Hr**

If any item defined in the options of “Power Down and Resume events” is enabled & active, STANDBY timer will be reloaded. When the system has entered Standby mode , any of the items that are enabled in “Wake Up Events of Doze and Standby” will trigger the system to wake up.

Suspend Mode**Disable**

System will never enter SUSPEND mode.

1 Min/2 Min/

Defines the continuous idle time before the system enters SUSPEND mode.

4 Min/8 Min/**12 Min/20 Min/****30 Min/40 Min/****1 Hr**

If any item defined in the options of “Power Down & Resume Events” is enabled & active, SUSPEND timer will be reloaded. When the system has entered SUSPEND mode, any of the items enabled in the “Power Down & Resume Events” will trigger the system to wake up.

HDD Power Down**Disable**

HDD’s motor will not shut off.

1 Min/2 Min/

Defines the continuous HDD idle time before the HDD enters the power saving mode (motor off). BIOS will turn off the HDD’s motor when time is out.

3 Min/4 Min/**5 Min/6 Min/****7 Min/8 Min/****9 Min/10 Min/****11 Min/12 Min/****13 Min/14 Min/****15 Min**

Throttle Duty Cycle

This option will determine how much power will be used by the CPU , if the system goes into suspend mode.

PCI/VGA Act_Monitor

During Enabled, if there's no activity in the monitor screen, the system will go into Power Saving Mode. During Disabled, the system will go into Power Saving Mode, whether there is activity in the monitor screen or not. The settings are Disabled and Enabled.

Soft-Off by PWR-BTTN

The settings are Delay 4 sec or Instant-off. During Delay 4 sec, if you push the switch once, the system goes into suspend mode. If you push it more than 4 seconds, the system will be turned off. During instant-off, the system will turn off once you push the switch.

CPUFAN Off in Suspend

During Enabled, if the system goes into suspend mode, the CPU fan will stop. During Disabled, if the system goes into suspend mode, the CPU fan will resume.

Power On By Ring

During Disabled, the system will ignore any incoming call from the modem. During Enabled, the system will boot up if there's an incoming call from the modem.

Note: If you have change the setting, you must let the system boot up until it goes to the operating system, before this function will work.

Power Status LED

This item determines which status the Power LED will use. The settings are Blink, Dual Color, and Single Color. During Blink, the power LED will blink when the system enters the suspend mode. When the mode is in Dual Color, the power LED will change its color during suspend mode. Choose the Single Color and the power LED will always remain lit.

Resume by Alarm

This function is for setting date and time for your computer to boot up. During Disabled, you cannot use this function. During Enabled, choose the Date and Time Alarm:

Date(of month) Alarm You can choose which month the system will boot up. Set to 0, to boot very month.

Time(hh:mm:ss) Alarm You can choose what hour, minute and second the system will boot up.

Note: If you have change the setting, you must let the system boot up until it goes to the operating system, before this function will work.

Wake Up On LAN

To use this function, you need a LAN add-on card which support power on functions. It should also support the wake-up on LAN jumper (JWOL1).

Enabled Wake up on LAN supported.

Disabled Wake up on LAN not supported.

IRQ 8 Clock Event

You can Enable or Disable monitoring of IRQ 8 so it does not awaken the system from suspend mode.

Reload Global Timer Events

IRQ[3-7,9-15], NMI	: Enabled
Primary IDE 0	: Enabled
Primary IDE 1	: Disabled
Secondary IDE 0	: Disabled
Secondary IDE 1	: Disabled
Floppy Disk	: Enabled
Serial Port	: Enabled
Parallel Port	: Enabled

During Enabled, if any interrupt event occurs, the system will wake-up from suspend mode. During Disabled, the system will not monitor any interrupt event.

PNP/PCI Configuration Setup

You can manually configure the PCI Device's IRQ. The following pages tell you the options of each item & describe the meanings of each options.

ROM PCI/ISA BIOS (2A69HM4D)
PNP/PCI CONFIGURATION SETUP
AWARD SOFTWARE, INC.

PnP OS Installed	:No	Assign IRQ for VGA	: Enabled
Resources Controlled By	:Manual	Assign IRQ for USB	: Enabled
Reset Configuration Data	:Disabled	Used MEM base addr	: N/A
IRQ-3 assigned to	: PCI/ISA PnP		
IRQ-4 assigned to	: PCI/ISA PnP		
IRQ-5 assigned to	: PCI/ISA PnP		
IRQ-7 assigned to	: PCI/ISA PnP		
IRQ-9 assigned to	: PCI/ISA PnP		
IRQ-10 assigned to	: PCI/ISA PnP		
IRQ-11 assigned to	: PCI/ISA PnP		
IRQ-12 assigned to	: PCI/ISA PnP		
IRQ-14 assigned to	: PCI/ISA PnP		
IRQ-15 assigned to	: PCI/ISA PnP		
DMA-0 assigned to	: PCI/ISA PnP		
DMA-1 assigned to	: PCI/ISA PnP		
DMA-3 assigned to	: PCI/ISA PnP	Esc : Quit	↑↓→← : Select item
DMA-5 assigned to	: PCI/ISA PnP	F1 : Help	PU/PD/+/- : modify
DMA-6 assigned to	: PCI/ISA PnP	F5 : Old Value(Shift)	F2 : Color
DMA-7 assigned to	: PCI/ISA PnP	F6 : Load BIOS Defaults	
		F7 : Load Setup Defaults	

PnP OS Installed

When set to YES, BIOS will only initialize the PnP cards used for booting (VGA, IDE, SCSI). The rest of the cards will be initialized by the PnP operating system like Windows® 95 or 98. When set to NO, BIOS will initialize all the PnP cards. So, for non-PnP operating system (DOS, Netware®), this option must set to NO.

Resources Controlled By

By Choosing “Auto”, the system BIOS will detect the system resource and automatically assign the relative IRQ and DMA Channel for each peripheral.

By Choosing “Manual”(default), the user will need to assign IRQ & DMA for add-on cards. Be sure that there is no conflict for IRQ/DMA and I/O ports.

Note: When choosing “Auto”, you must be sure that all of the system add-on cards are PnP type.

Reset Configuration Data

The system BIOS supports the PnP feature so the system needs to record which resource is assigned and protect resources from conflict. Every peripheral device has a node which is called ESCD. This node records which resources are assigned to it. The system needs to record and update ESCD to the memory locations. These locations (4K) are reserved at the system BIOS.

If Disabled (default) is chosen, the system’s ESCD will update only when the new configuration varies from the last one.

If Enabled is chosen, the system will be forced to update the system’s ESCD. Then, this option will be auto-set to Disable.

IRQ-3	assigned to	: PCI/ISA	PnP
IRQ-4	assigned to	: PCI/ISA	PnP
IRQ-5	assigned to	: PCI/ISA	PnP
IRQ-7	assigned to	: PCI/ISA	PnP
IRQ-9	assigned to	: PCI/ISA	PnP
IRQ-10	assigned to	: PCI/ISA	PnP
IRQ-11	assigned to	: PCI/ISA	PnP
IRQ-12	assigned to	: PCI/ISA	PnP
IRQ-14	assigned to	: PCI/ISA	PnP

IRQ-15 assigned to : PCI/ISA PnP
DMA-0 assigned to : PCI/ISA PnP
DMA-1 assigned to : PCI/ISA PnP
DMA-3 assigned to : PCI/ISA PnP
DMA-5 assigned to : PCI/ISA PnP
DMA-6 assigned to : PCI/ISA PnP
DMA-7 assigned to : PCI/ISA PnP

The above settings will be shown on the screen only if “Manual” is chosen for the *Resources Controlled By* function.

Legacy is the term which signifies that a resource is assigned to the ISA Bus and provides for non PnP ISA add-on card. PCI/ISA PnP signifies that a resource is assigned to the PCI Bus or provides for ISA PnP add-on cards and peripherals.

Assign IRQ for VGA

Lets the user choose which IRQ to assign for VGA card.

Assign IRQ for USB

Set to Enabled when USB port will be used. Set to Disable if the USB port will not be used.

Used MEM base addr

Lets the user choose the Legacy ISA addr. The settings are NA#, C800, CC00, D000, D400, D800 or DC00.

Load BIOS/Setup Defaults

This Main Menu item loads the default system values. If the CMOS is corrupted, the defaults are loaded automatically. Choose this item and the following message appears:

“ Load Setup Defaults (Y / N) ? N “

To use the Setup defaults, change the prompt to “Y” and press < Enter >

Note: The Setup defaults can be customized to increase performance. However the BIOS defaults can always be used as a back up if there is some problem with the mainboard operation.

CPU Plug & Play III

This Special Features Setup is used by System Hardware Monitor chipset. You can manually change the value of each option.

ROM PCI/ISA BIOS (2A69HM4C)
CPU Plug & Play III
AWARD SOFTWARE, INC.

*****CPU PLUG & PLAY II*****	***** SYSTEM MONITOR *****
Adjust CPU Voltage :2.00V	CPU Fan RPM :6367
CPU Host/PCI Frequency :Auto	System Temperature :28°C/82°F
***** POST SHOWING *****	CPU Temperature :28°C/82°F
Power Fan Detected :Disabled	TOP TECH. III :Disabled
Chassis Fan Detected :Disabled	CPU Critical Temp :Disabled
CPU Fan Detected :Enabled	Shutdown Temp :Disabled
Chassis Intrusion Detect :Disabled	
Voltage Detected :Enabled	
Vcore Voltage Detected :Enabled	
+1.5V Voltage Detected :Enabled	
+3.3V Voltage Detected :Enabled	
+5.0V Voltage Detected :Enabled	
+ 12V Voltage Detected :Enabled	
- 12V Voltage Detected :Enabled	
-5.0V Voltage Detected :Enabled	
	Esc : Quit ↑↓→← : Select item
VBat Voltage Detected :Enabled	F1 : Help FU/PD/+/- : modify
5VSB Voltage Detected :Enabled	F5 : Old Value(Shift) F2 : Color
	F6 : Load BIOS Defaults
	F7 : Load Setup Defaults

Adjust CPU Voltage

This function is used to adjust the CPU voltage. During overclocking, the processor might get unstable. Try adjusting the CPU voltage to lessen the heat generated by the CPU voltage.

NOTE: We do not guarantee that Motherboard or other components will work properly after overclocking.

CPU Host/PCI Frequency

Check your processor and set this function accordingly. You can set the CPU Frequency accordingly. CPU Frequencies are: 66, 68, 75, 83 and 100, 103, 112, 117, 124, 129, 133, 138, 143, 148, 153. **Though 68, 75, 83, 103, 112, 117, 124, 129, 133, 138, 143, 148 and 153 frequencies are available, it is advised that you use these only for testing since this is not stable as the CPU is not designed for these frequencies.**

Note: If the CPU Bus Frequency is set too high, the system may not bootup, then restart the system. Press “F10” until bootup. This will set the default setting.

Power Fan Detected/Chassis Fan Detected/CPU Fan Detected/+1.5V Voltage Detected/Vcore Voltage Detected/+3.3V Voltage Detected/+5.0 Voltage Detected/+12V Voltage Detected/-12V Voltage Detected/-5.0 Voltage Detected/VBat Voltage Detected/5VSB Voltage Detected

During Enabled, this will show the CPU/FAN voltage chart during system boot up. During Disabled, this will not show.

Chassis Intrusion Detect

Set this option to Enabled, Reset, or Disabled the chassis intrusion detector. During Enabled, any intrusion on the system chassis will be recorded. The next time you turn on the system, it will show a warning message. To be able to clear those warning, choose Reset. After clearing the message it will go back to Enabled.

Chassis/CPU Fan RPM

During Enabled, this will monitor the RPM of your CPU/Chassis fan.

System Temperature

This will show the system temperature.

CPU Temperature

This will show the CPU temperature.

TOP TECH. III

This option is used to disabled or enabled the J2 connector 20 cm thermistor. The default setting is Disabled (See page 2-28). When choose Enabled, "TOP TECH III Temp" item will appear onscreen.

CPU Critical Temp

This option is for setting the critical temperature level for the processor. When the processor reach the temperature you set, this will reduce the load on the processor.

Shutdown Temp

This option is for setting the Shutdown temperature level for the processor. When the processor reach the temperature you set, this will shutdown the system. This function only works with Windows® 98 operating system.

Integrated Peripherals

ROM PCI/ISA BIOS (2A69HM4D)
 INTEGRATED PERIPHERALS
 AWARD SOFTWARE, INC.

IDE HDD Block Mode	:Enabled	Onboard FDC Controller	:Enabled
IDE Primary Master PIO	:Auto	Onboard Serial Port 1	:3F8/IRQ4
IDE Primary Slave PIO	:Auto	Onboard Serial Port 2	:2F8/IRQ3
IDE Secondary Master PIO	:Auto	UART Mode Select	:Normal
IDE Secondary Slave PIO	:Auto		
IDE Primary Master UDMA	:Auto	Onboard Parallel Mode	:378/IRQ7
IDE Primary Slave UDMA	:Auto	Parallel Port Mode	:SPP
IDE Secondary Master UDMA	:Auto		
IDE Secondary Slave UDMA	:Auto	Pwron After PWR-Fail	:Off
On-Chip Primary PCI IDE	:Enabled		
On-Chip Secondary PCI IDE	:Enabled		
USB Keyboard support	:Disabled		
Init Dislay First	:PCI slot		
Power On Function	:Button Only	Esc : Quit	↑↓→← : Select item
		F1 : Help	PU/PD/+/- : modify
		F5 : Old Value(Shift)	F2 : Color
		F6 : Load BIOS Defaults	
		F7 : Load Setup Defaults	

IDE HDD Block Mode

Enabled/Disabled Enabled allows the Block mode access for the IDEHDD.

IDE Primary Master PIO

Auto/Mode0/Mode1-4

IDE Primary Slave PIO

Auto/Mode0/Mode1-4

IDE Secondary Master PIO

Auto/Mode0/Mode1-4

IDE Secondary Slave PIO

Auto/Mode0/Mode1-4

For these 4 IDE options, choose “Auto” to have the system BIOS auto detect the IDE HDD operation mode for PIO access.

Note: Some IDE HDD cannot operate at the responding HDD’s mode. When the user has selected “Auto” and the system BIOS has accepted the HDD response mode, the user may degrade the HDD’s operation mode. Ex: IF the HDD reported that it can operate in mode 4 but it is not operating properly, the user will have to manually change the operation mode to mode 3.

Choosing Mode 1-4 will have the system ignore the HDD’s reported operation mode and use the selected mode instead.

Note: According to ATA specs. Mode 4 transfer rate is > Mode 3 > Mode 2 > Mode 1 > Mode 0. If the user’s HDD can operate at Mode 3 the user can also select a slower Mode (i.e. Mode 0-2) but not a faster Mode (ie Mode 4).

On-Chip Primary PCI IDE

On-Chip Secondary PCI IDE

The system provides for an On-Board On-Chipset PCI IDE controller that supports Dual Channel IDE (Primary and Secondary). A maximum of 4 IDE devices can be supported. If the user install the Off-Board PCI IDE controller (i.e. add-on cards), the user must choose which channels will be disabled. This will depend on which channel will be used for the Off-Board PCI IDE add-on card.

USB Keyboard Support

Choosing Enabled will allow the system to use USB keyboard without a device driver.

Init Display First

PCISlot

If both PCI VGA card and AGP card are installed, the system will display the PCI VGA card first.

AGP

If both PCI VGA card and AGP card are installed, the system will show the AGP card first.

Power ON Function

This function allows you to select Button only, Keyboard 98, Password, Mouse Left or Mouse Right, and Hot Key (Ctrl F1 to Ctrl F12) which feature the same function to Power ON the system.

Note: If you choose Mouse Left or Mouse Right, you must let the system boot up until it goes to the BIOS table configuration, before this function will work. During Power OFF, double click the left or right mouse button to Power ON the system.

Onboard FDC Controller

The system has an on-board Super I/O chip with a FDD controller that supports 2 FDDs for 360K/720K/1.2M/1.44M/2.8M. Choose “Enabled” to use the on-board FDD controller for accessing the FDD. Otherwise choose “Disabled” to use the off-board FDD controller.

Onboard Serial Port 1

Disabled/(3F8/IRQ4)/(2F8/IRQ3)/(3E8/IRQ4)/(2E8/IRQ3)

Onboard Serial Port 2

Disabled/(3F8/IRQ4)/(2F8/IRQ3)/(3E8/IRQ4)/(2E8/IRQ3)

The system has an On-board Super I/O chipset with 2 serial ports. The On-board serial ports can be selected as:

Disabled

3F8/IRQ4	COM 1 uses IRQ4
2F8/IRQ3	COM 2 uses IRQ3
3E8/IRQ4	COM 3 uses IRQ4
2E8/IRQ3	COM 4 uses IRQ3

Note: Because the ISA Bus Interrupt accepts low to high edge trigger, the interrupt request line cannot be shared by multiple sources. If an off-board ISA add-on card with a serial port is installed the user may have to disable the on-board serial port because it will conflict with IRQ request line for the off-board serial port.

UART Mode Select

This item allows you to determine which InfraRed (IR) function of the onboard I/O chip, this function uses.

278H/IRQ5	Line Printer port 2
378H/IRQ5	Line Printer port 1

Onboard Parallel Mode

Disabled

(3BCH/IRQ7)/

(278H/IRQ5)/

(378H/IRQ5)

There is a built-in parallel port on the on-board Super I/O chipset that provides Standard, ECP, and EPP features. It has the following options:

Disable

3BCH/IRQ7

Line Printer port 0

278H/IRQ5

Line Printer port 2

378H/IRQ5

Line Printer port 1

Parallel Port Mode

SPP : Standard Parallel Port

EPP : Enhanced Parallel Port

ECP : Extended Capability Port

**SPP/(EPP/SPP)/
ECP(ECP/EPP)**

To operate the onboard parallel port as Standard Parallel Port only, choose "SPP." To operate the onboard parallel port in the ECP and SPP modes simultaneously, choose "ECP/SPP." By choosing "ECP", the onboard parallel port will operate in ECP mode only. Choosing "ECP/EPP" will allow the onboard parallel port to support both the ECP and EPP modes simultaneously. The ECP mode has to use the DMA channel, so choose the onboard parallel port with the ECP feature. After selecting it, the following message will appear: "ECP Mode Use DMA" At this time, the user can choose between DMA channels 3 or 1. The onboard parallel port is EPP Spec. compliant, so after the user chooses the onboard parallel port with the EPP function, the following

message will be displayed on the screen: “EPP Mode Select.” At this time either EPP 1.7 spec. or EPP 1.9 spec. can be chosen.

PWRON After PWR-FAIL

This option will determine how the system will power on after a power failure.

Supervisor/User Password Setting

This Main Menu item lets you configure the system so that a password is required each time the system boots or an attempt is made to enter the Setup program. Supervisor Password allows you to change all CMOS settings but the User Password setting doesn't have this function. The way to set up the passwords for both Supervisor and User are as follow:

1. Choose "Change Password" in the Main Menu and press <Enter>. The following message appears:

"Enter Password:"

2. The first time you run this option, enter your password up to 8 characters only and press <Enter>. The screen will not display the entered characters. For no password, just press <Enter>.
3. After you enter the password, the following message appears prompting you to confirm the password:

"Confirm Password:"

4. Enter exactly the same password you just typed in to confirm the password and press <Enter>.
 5. Move the cursor to Save & Exit Setup to save the password.
 6. If you need to delete the password you entered before, choose the Supervisor Password and press <Enter>. It will delete the password that you had before.
 7. Move the cursor to Save & Exit Setup to save the option you did. Otherwise, the old password will still be there when you turn on your machine next time.
-

IDE HDD Auto Detection

You can use this utility to automatically detect the characteristics of most hard drives.

When you enter this utility, the screen asks you to select a specific hard disk for Primary Master. If you accept a hard disk detected by the BIOS, you can enter “Y” to confirm and then press <Enter> to check next hard disk. This function allows you to check four hard disks and you may press the <Esc> after the <Enter> to skip this function and go back to the Main Menu.

**ROM ISA BIOS
CMOS SETUP UTILITY
AWARD SOFTWARE, INC.**

HARD DISKS	TYPE	SIZE	CYLS	HEADS	PRECOMP	LANDZONE	SECTOR MODE
Primary Master:	Auto	0	0	0	0	0	AUTO
Primary Slave :	Auto	0	0	0	0	0	AUTO
Secondary Master :	Auto	0	0	0	0	0	AUTO
Secondary Slave :	Auto	0	0	0	0	0	AUTO

Select Primary Master		Option (N=Skip) : N				
OPTIONS	SIZE	CYLS	HEAD	PRECOMP	LANDZ	SECTOR MODE
2	2112	1023	64	0	4094	63 LBA
1	2113	4095	16	65535	4094	63 NORMAL
3	2113	2047	32	65535	4094	63 LARGE

[ESC: Skip]

Chapter 4

CREATIVE® AUDIO DRIVER (Optional)

1. Overview

The Creative® ES1373 digital controller provides the next generation of audio performance to the PC market.

1.1 Features

- SoundScape WaveTable Synthesizer.
- Full DOS Game Compatibility.
- PCI Bus Master for fast DMA.
- Fully Compliant with PC97 Power Management Specification.

1.2 System Requirements

This section describes system requirements for the Audio Driver installation and Usage.

Computer	Intel® Pentium® II/Celeron™ processor or higher
Operating system	DOS 5.0 or higher, Windows® 95/98, Windows® NT 3.51 or 4.0, or OS/2®
CD-ROM	Double Speed or Higher
Chipset	Creative® ES1373

2. Audio Driver Setup & Usage Procedures

Insert the CD-title into your CD-ROM drive. This CD will auto-run. This will display installation for VGA driver and sound driver. Also included are Intel® PIIX4 patch for Windows® 95/98, Trend PC-cillin 98, and Bus Master driver. Just click the button for automatic installation for audio driver.

2.1 Windows® 95/98

If you start Windows® 95/98, this will automatically detect this hardware onboard “PCI Multimedia Audio Device” and “Gameport Joystick”. You need to click “Next”, then “Finish”. Do not click on the “Cancel”. The driver need these ID.

2.1-1 Audio Driver Installation Procedure:

- Step 1:** Insert the provided CD-ROM disk into the CD-ROM drive.
- Step 2:** Look for the CD-ROM drive, double click on the CD-ROM icon. This will show the setup screen.
- Step 3:** Click on “Creative AudioPCI” sound drivers icon.
- Step 4:** This will copy the audio drivers into the hard drive.
- Step 5:** A message will appear stating you must restart the Windows® 95/98 system, select **yes** to restart.

2.2 Windows® NT 4.0

2.2-1 Audio Driver Installation Procedure:

- Step 1:** Click **Start** menu and select **Control Panel** from **Settings** group.
- Step 2:** Select **Multimedia** icon.
- Step 3:** Click on the **Devices** tab.
- Step 4:** Click **Add**.
- Step 5:** Double click on **Unlisted or Updated Driver** in the list.
- Step 6:** Insert the **CD-ROM Disk** into the CD-ROM Drive.
- Step 7:** When the Install from Disk dialog box appears, look for your CD-ROM drive :**\Sound\ Creative\AudioPCI\Drivers \NT40\English\I386\CD**
- Step 8:** Click **OK**.
- Step 9:** Click **OK**.
- Step 10:** A message will appear stating that the drivers were successfully installed. Click **OK**. You must now restart Windows® NT 4.0.

2.3 Detailed User's Manual

The detailed user's manual can be found on following path of the CD-ROM provided:

PATH: Sound\Creative\AudioPCI\Docs\Manual.doc